

INSTALLATION

NOTICE DE MONTAGE PORTE COULISSANTE LATÉRALE REFOULEMENT À 90° USINE-ONLINE

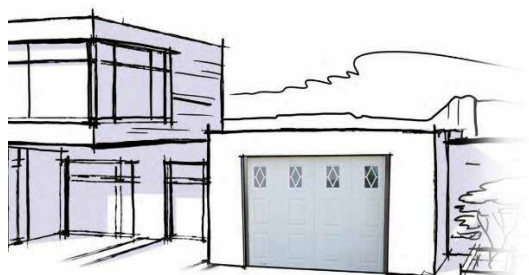

**Déplacement Latéral Cadre
sans Portillon**
Motorisée/Manuelle - Refoulement 90°

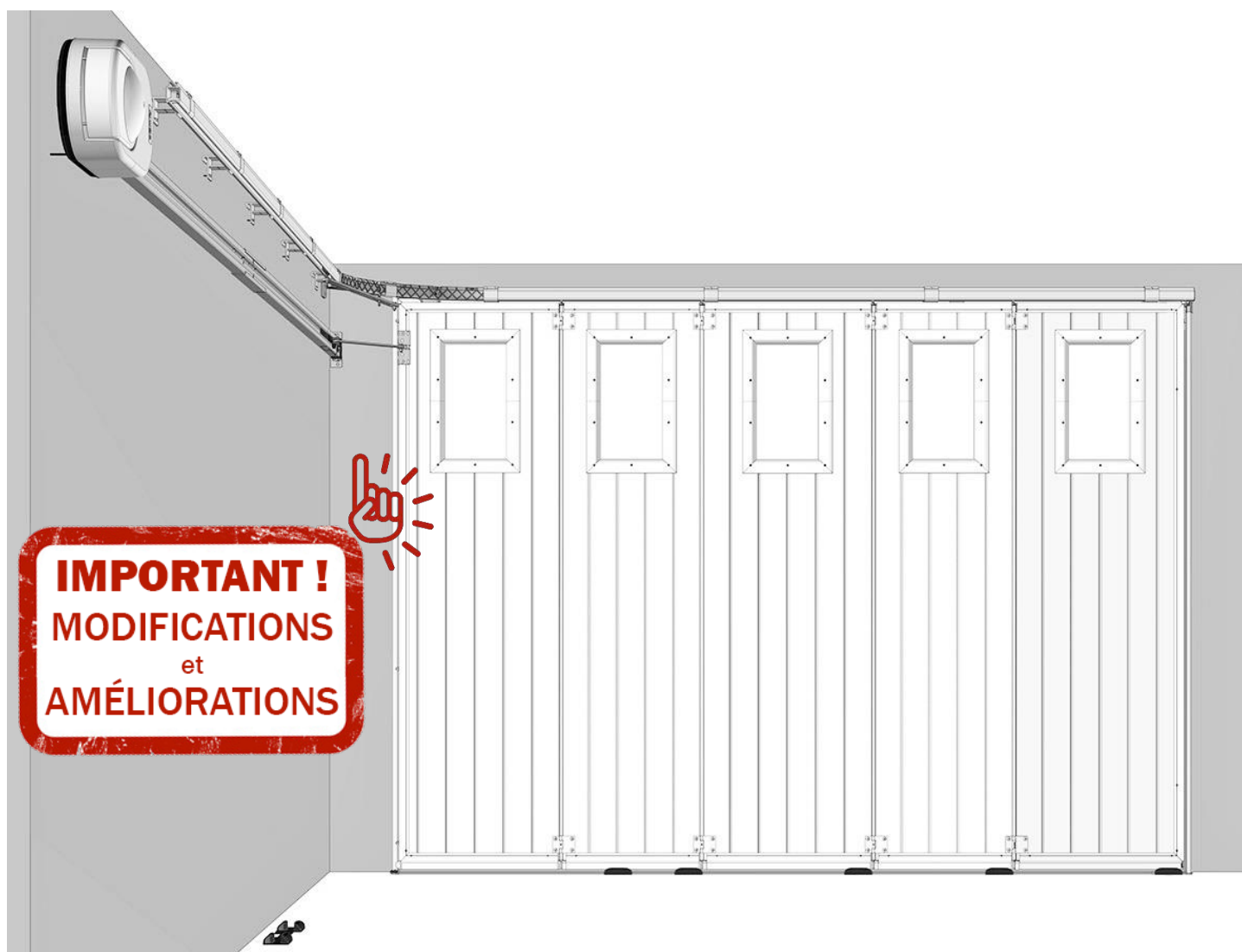

(Document réservé aux installateurs)

Sommaire

Instructions d'installation	3
Avant la pose	4
Matériel nécessaire	4
Contenu des kits selon configuration/options de la porte	5
Accessoires en standard	5
Accessoires en motorisation	6
Accessoires en option porte motorisée ou en standard porte manuelle	6
Accessoires en option porte motorisée et manuelle	6
Vérification des surfaces	7
Cadre support	7
Montage et découpe des joints	7
Montage des patins	8
Pièces nécessaires	9
Assemblage du cadre au sol	10
Installation du cadre	10
Cadre de refolement (Refolement à gauche représenté)	12
Rail côté baie (Refolement à gauche représenté)	14
Assemblage du "rail de guidage haut" sur le sol	14
Assemblage et montage du support de cintre	15
Assemblage du cintre	15
Montage du rail de guidage	16
Assemblage du cintre (partie 2)	17
Fixer les 2 supports	17
Butée tablier (Refolement à gauche représenté)	18
Préparation de la butée	18
Montage de la butée	18
Tablier (Refolement à gauche représenté)	19
Vue d'ensemble	19
Préparation du panneau côté opposé au refolement	20
Préparation des panneaux intermédiaires	21
Assemblage des panneaux côté opposé au refolement & intermédiaire	22
Installation des panneaux côté opposé au refolement & intermédiaire	23
Préparation du panneau côté refolement	24
Installation des panneaux intermédiaires par 2 ou avec panneau côté refolement	26
Contrôler la position du tablier	27
Contrôler le parallélisme	27
Assemblage du "rail de guidage haut" sur le sol	28
Montage du rail de guidage	29
Les différents équipements côté refolement	30
3 cas possibles (Refolement à gauche représenté)	30
Bras multiposition pour écoinçon : $175 \leq \text{ECR} \leq 585 \text{ mm}$	31
Montage du bras	31
Rallonge pour écoinçon : $585 < \text{ECR} \leq 1000 \text{ mm}$	32
Préparation de la rallonge	32
Montage de la rallonge	32
Pas d'équipement pour écoinçon : $\text{ECR} > 1000 \text{ mm}$	33
Finitions pour tous les types d'écoinçons	33
Montage de la butée de fin de course	33
Réglage des patins	34
Montage du guidage	34
Système de placage du tablier (panneau côté refolement)	35
Options	36
Serrure : Montage de la rosace	36
Montage de la poignée encastrée	37
Montage du verrou bas	37
Montage du verrou haut (HP = 2200 mm maxi)	38
Montage pour écoinçon refolement	39
1000 mm < ECR < Motorisation en baie	39
Préparation du support multi-moteurs	39
Montage du support multi-moteurs	39

Instructions d'installation



Pour que le montage, l'utilisation et l'entretien de ce produit soient réalisés en toute sécurité, il est nécessaire de suivre les instructions données ici.

Pour la sécurité de tous, respectez les mesures de précaution ci-dessous.

Avant de procéder au montage, lisez attentivement cette notice.

Cette fermeture doit être installée par un installateur professionnel.

Toutes les pièces livrées sont calculées spécifiquement pour ce produit.

Ajouter et/ou utiliser d'autres éléments peut être préjudiciable à la sécurité et à la garantie du produit.

Toute modification ou amélioration de cette fermeture doit être conforme à la norme EN 13241 + A2.

Dans ce cas, un dossier " Modification/Transformation " doit être établi par l'installateur suivant la norme EN 12635 annexe C.

Travailler en respectant les consignes de sécurité.

Utiliser les outils nécessaires à la mise en œuvre des produits.

Veiller à travailler sur un sol stable.

Veiller à avoir un espace de montage suffisamment lumineux, dégagé, propre et balisé.

Veiller à ce qu'aucune autre personne que les installateurs ne soit présente sur le chantier.

En effet, les personnes non autorisées comme les enfants, pouvant être présents sur le chantier, risquent de se blesser durant le montage.

Tous les composants de cette fermeture doivent être installés conformément aux instructions d'installations stipulées dans cette notice.

Toutes les exigences des normes EN 13241 + A2 doivent être satisfaites et vérifiées, si nécessaire.

Couple maxi de serrage :

Vis d'assemblage = 10 Nm

Vis de montage tablier = 12 Nm

Charge de service mini par patte équerre = 40 daN

Avant la pose

Matériel nécessaire

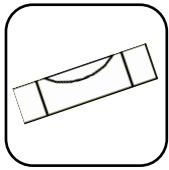

Niveau à bulle

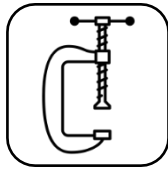

Serre-joints

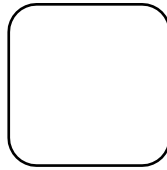

Niveau laser

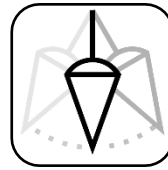

Fil à plomb

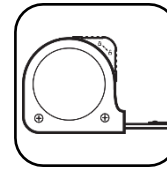

Mètre (8 m)

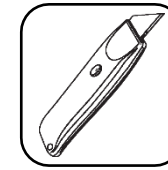

Cutter

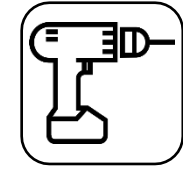

Visseuse

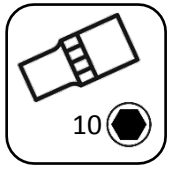

Douille



Embout
cruciforme



Embout Torx



Embout carré
(fourni)

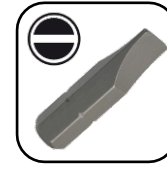

Embout plat



Embout
hexagonal

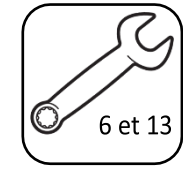

Clé plate

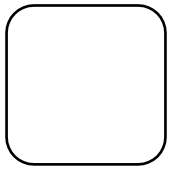

Tournevis
cruciforme



Tournevis
plat

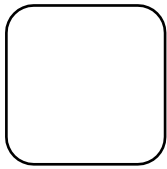

Crayon



Maillet



Marteau

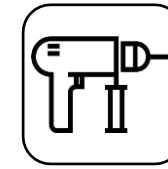

Perforateur

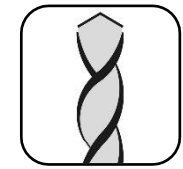

Forets acier
long. maxi 30 mm

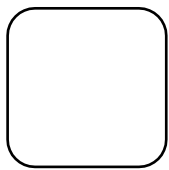

Pince étau

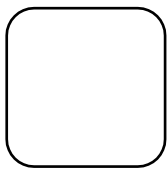

Règle
de maçon



Tréteaux

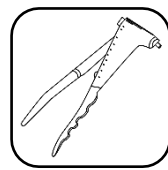

Pince
à riveter

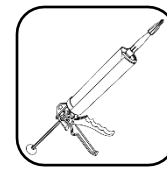

Joint silicone
(conseillé)



Echelle

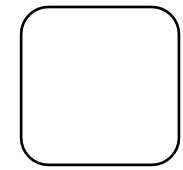

Lubrifiant

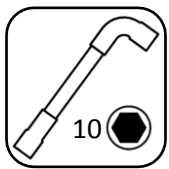

Clé à pipe

Chevilles et vis adaptées

Cales en plastique (fournies)

Contenu des kits selon configuration/options de la porte

Accessoires en standard

KIS-033 ou KIS-039
(charnières centrales)



KIS-600 (courbe)

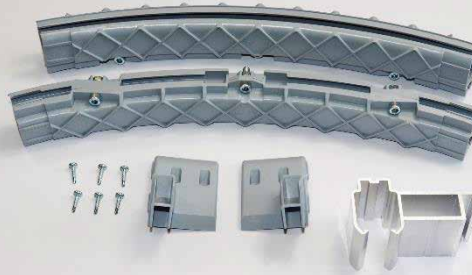

KIS-605 ou KIS-606
(supports de rail côté refolement)

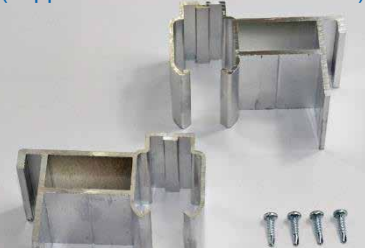

KIS-607 ou KIS-608
(supports de rail côté baie)



KIS-612 avec ASC-167 (bras multiposition)*



KIS-620 (kit de dépannage)



KIS-624 (support chariot)*

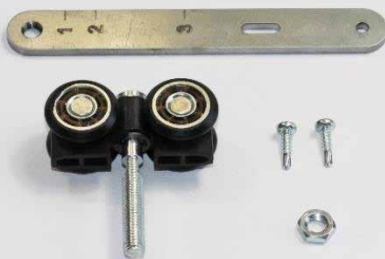

KIS-621 ou KIS-622 (rallonge)*



KIS-627 ou KIS-628*
(système de placage)



KIS-629 (système de placage)*



KIS-660 (accessoires cadre & guidage)

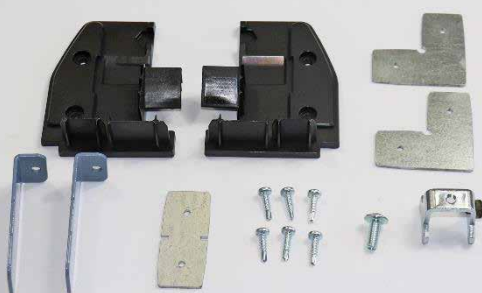

KIS-663 ou KIS-664
(patins de guidage intermédiaires)



KIS-665 (patin d'extrémité/verrou)



JNT-064 (joints brosse)



ASC-588 (tube renfort de courbe)



JNT-066 (joint caoutchouc)



*En fonction des écoinçons

Accessoires en motorisation

KIS-640 (kit motorisation Sommer)



Avec moteur au plafond ou au linteau

KIS-643 (kit motorisation Somfy)



Avec moteur au plafond ou au linteau

KIS-641 (vis pour bras Sommer)*



AMO-068 (bras pour moteur TD)*



AMO-504 (bras pour moteur TD500)*



Accessoires en option porte motorisée OU en standard porte manuelle

KIS-635 (poignée encastrée)



KIS-670 (verrou bas)



Accessoires en option porte motorisée et manuelle

KIS-634 (verrou haut)



CYL-016 (cylindre nicklé)



PGN-023 (paire de rosace)



*En fonction des écoinçons

Vérification des surfaces



Vérifier les planétés des zones écoinçons et retombée de linteau

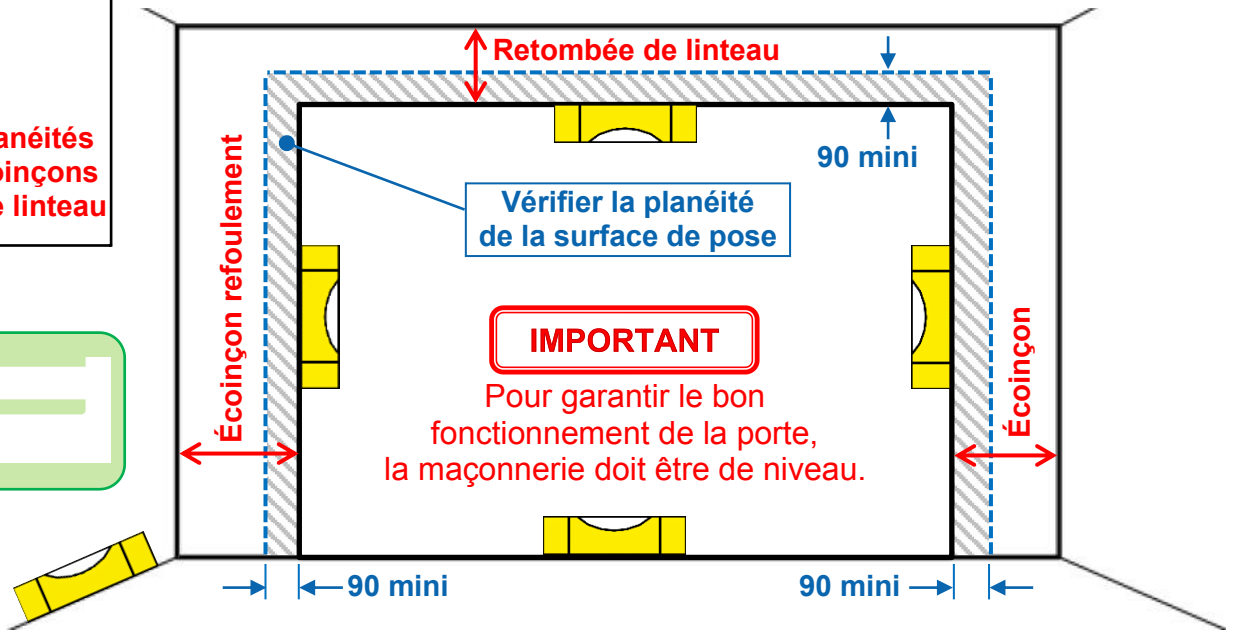

IMPORTANT

Pour garantir le bon fonctionnement de la porte, la maçonnerie doit être de niveau.

IMPORTANT : Refoulement à gauche décrit

Cadre support

Montage et découpe des joints

- **Au linteau** : Joint caoutchouc 35 mm

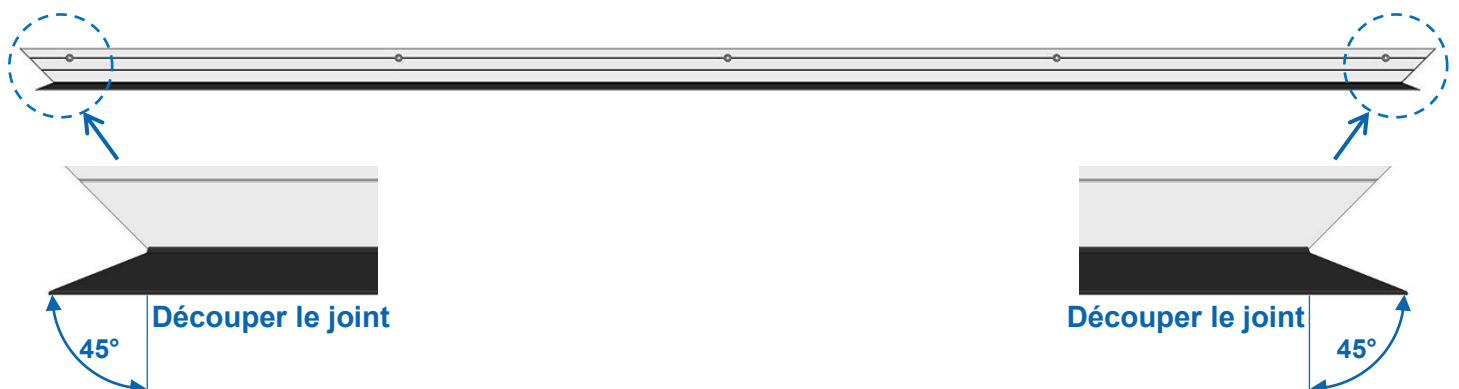

• **Côté refolement :**

• **Côté opposé refolement :**

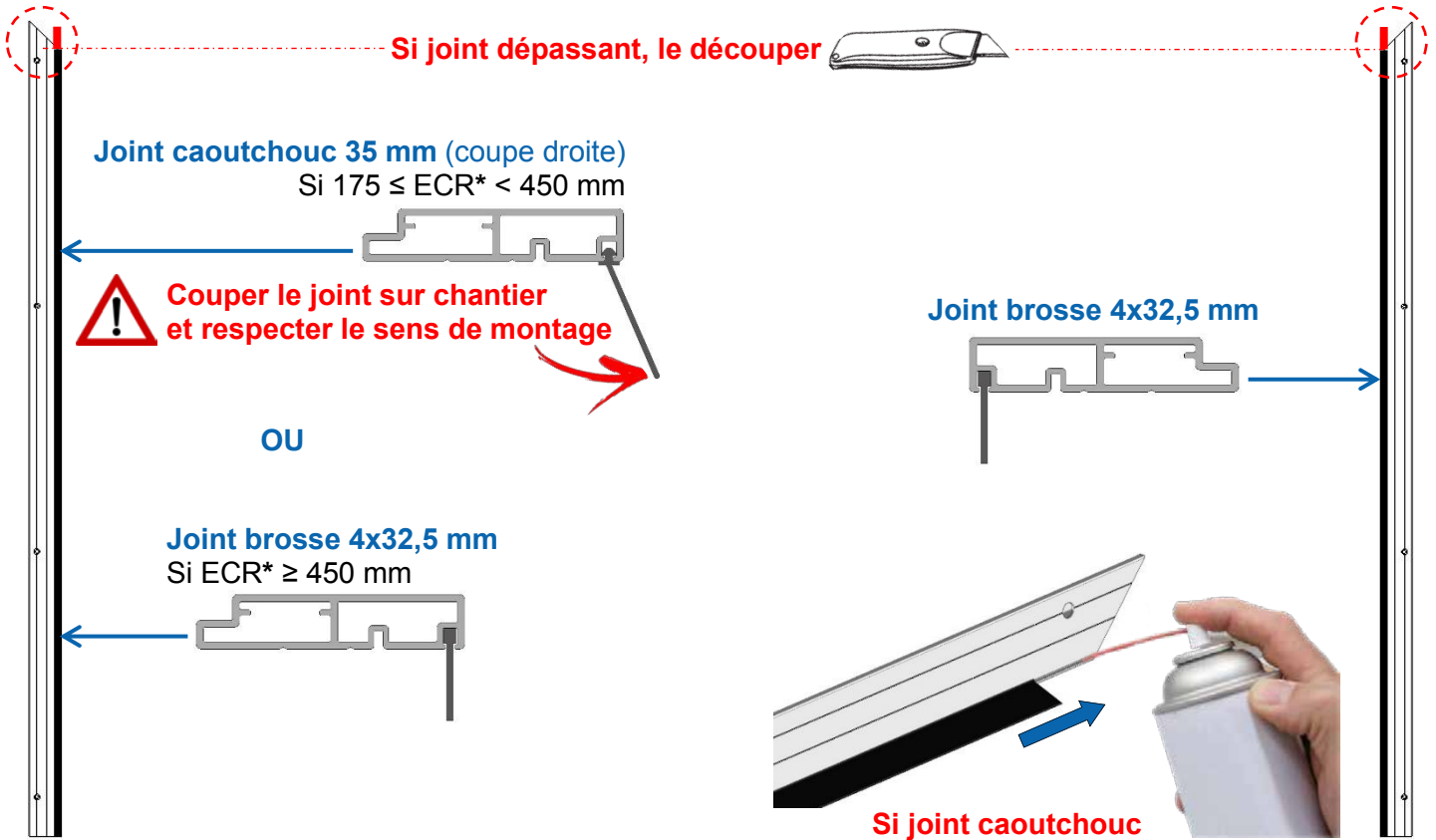

*ECR = Écoinçon Côté Refolement

Montage des patins

1- Assembler les patins intermédiaires

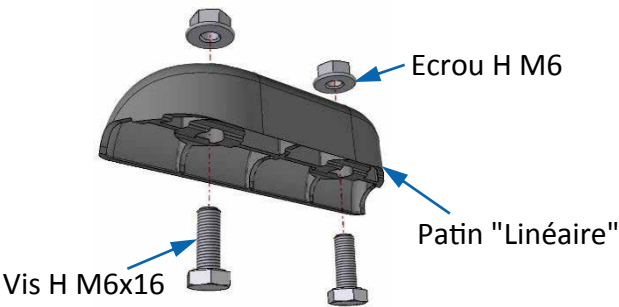

2- Assembler le(s) patin(s) Portillon/Verrou

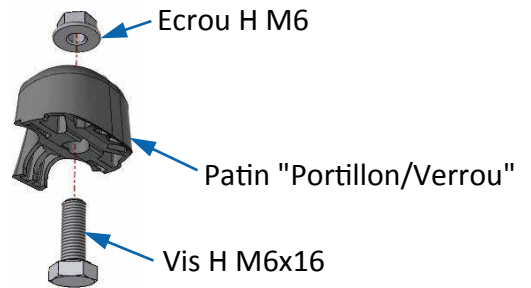

3- Glisser les patins sur le seuil, sans serrer les écrous

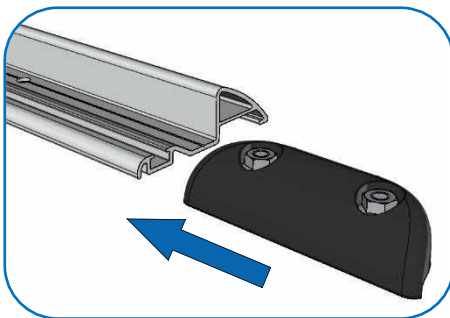

La position des patins sera réalisée après le montage du tablier



LOGIQUE DE MONTAGE DES PATINS

SANS VERROU

← Refoulement à gauche



Refoulement à droite →

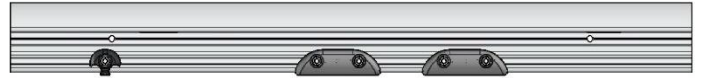

AVEC VERROU



Prévoir le montage du patin "portillon/verrou" entre les patins linéaires.

← Refoulement à gauche



Refoulement à droite →

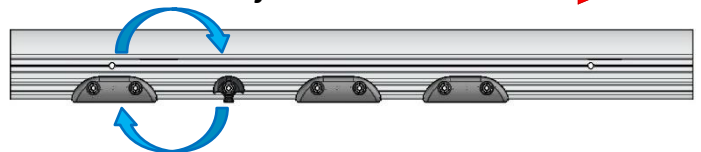

Nota : Pour plus d'informations sur la combinaison des patins, voir chapitre : "Finitions → Réglage des patins".

Pièces nécessaires

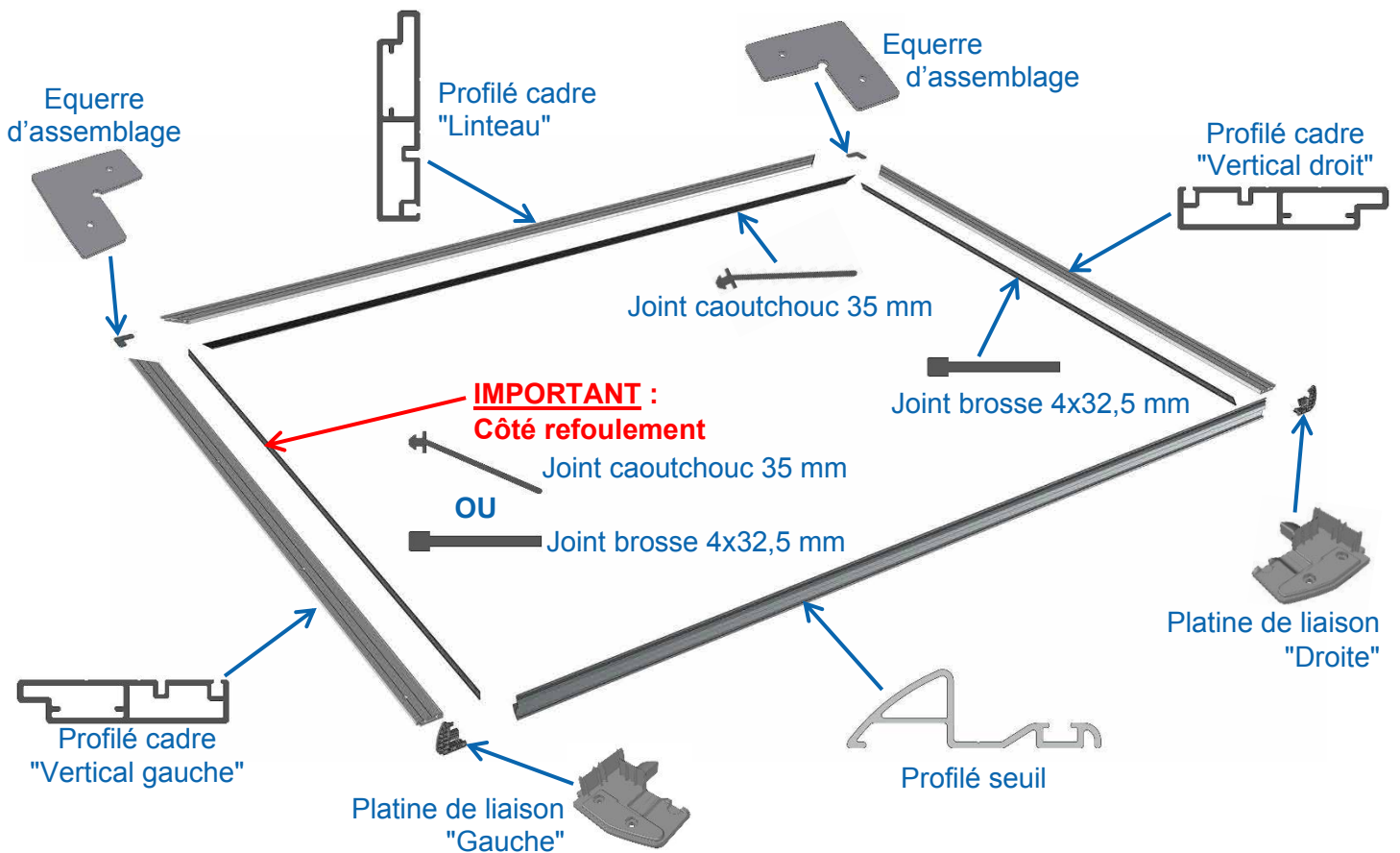

Assemblage du cadre au sol

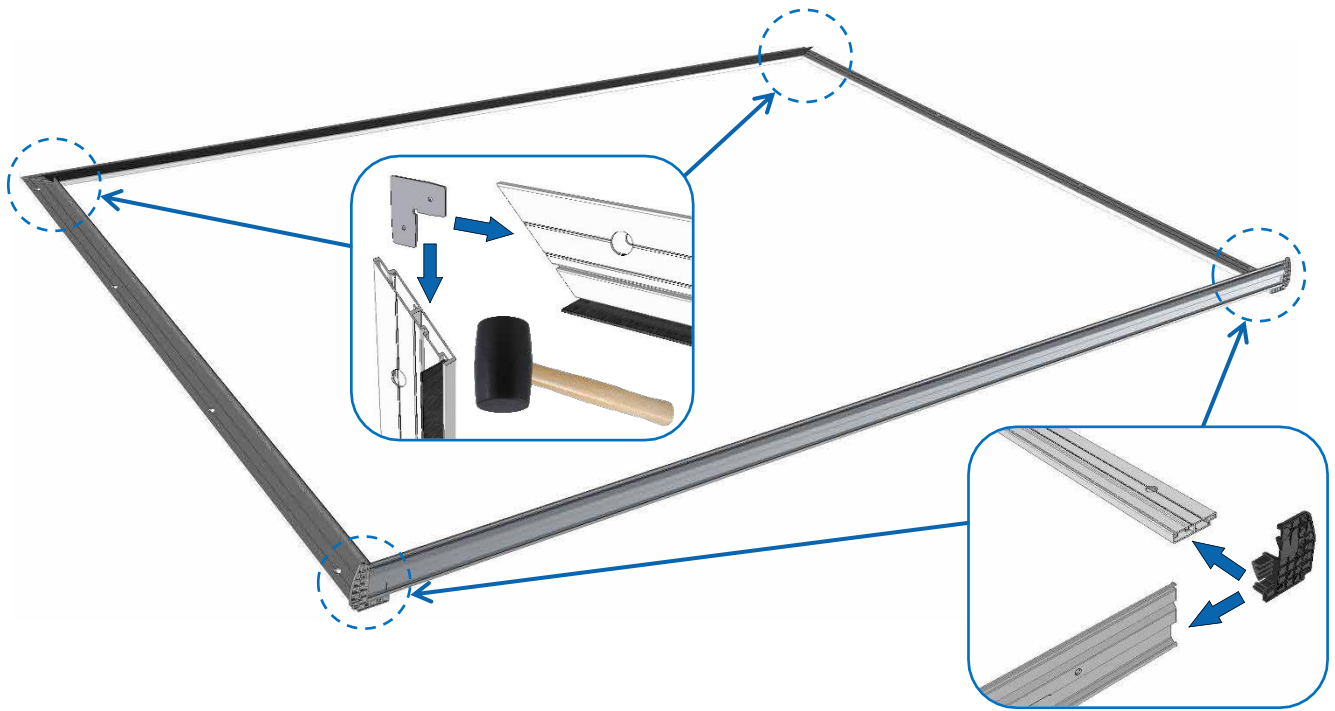

Installation du cadre

- Relever le cadre dans la baie :

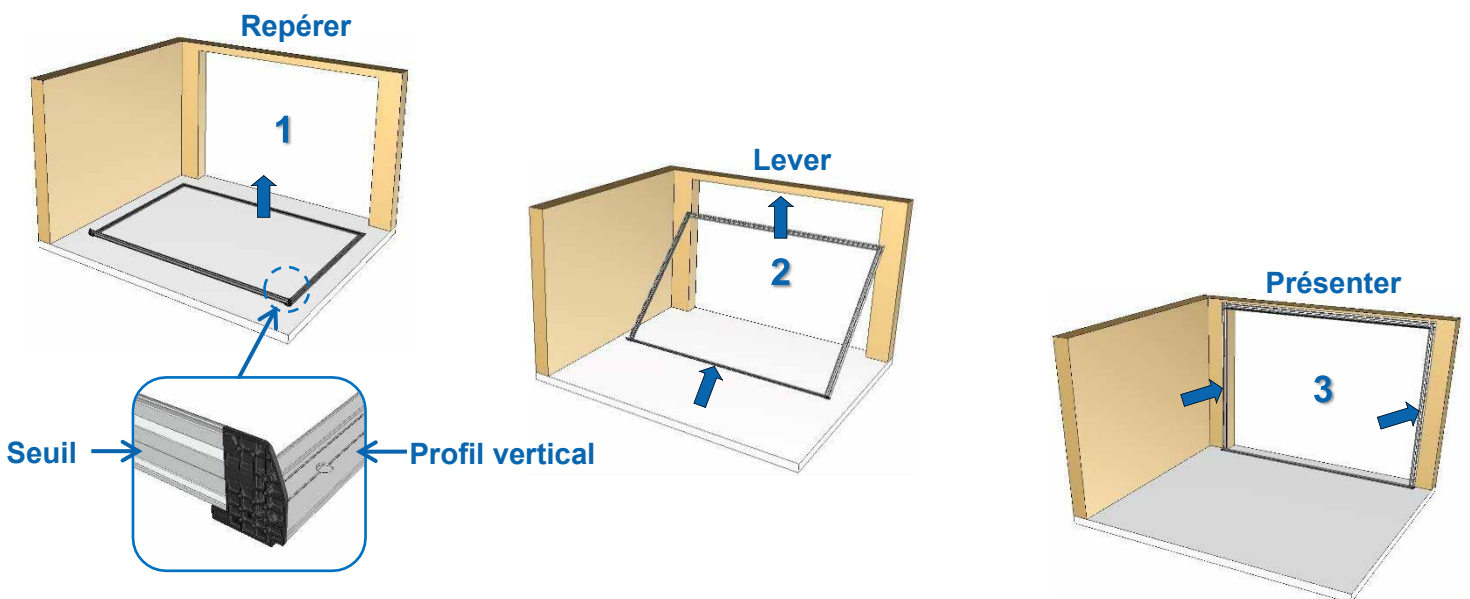

Conseil : Rajouter un **joint silicone** pour assurer l'étanchéité (silicone non fourni).

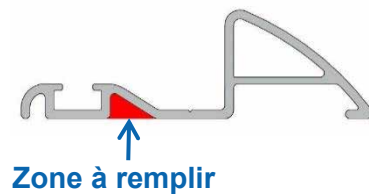

• **Positionner le cadre de niveau, d'aplomb et d'équerre :**

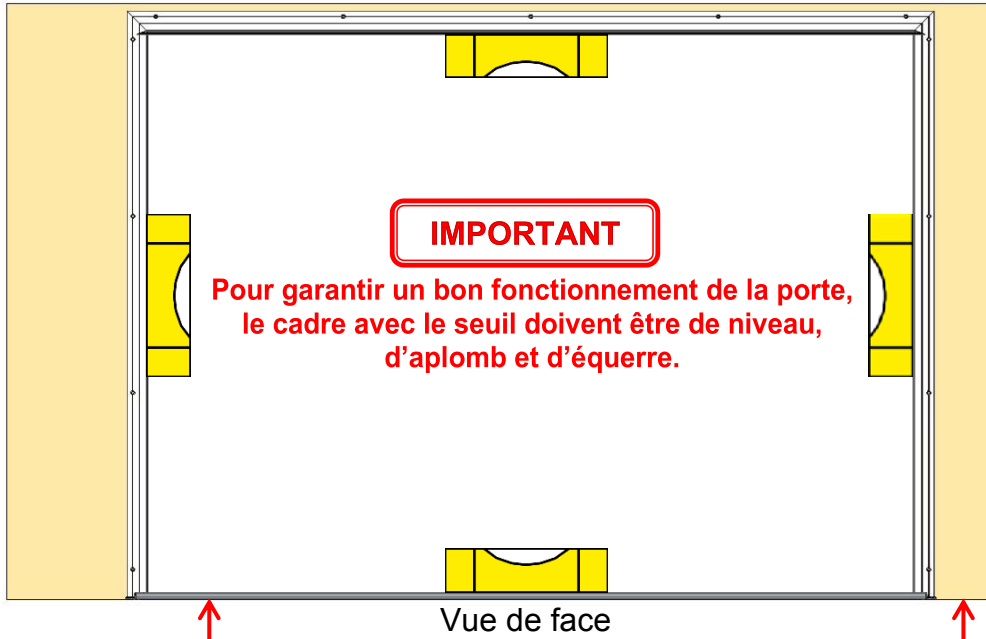

! D'aplomb et bien plan

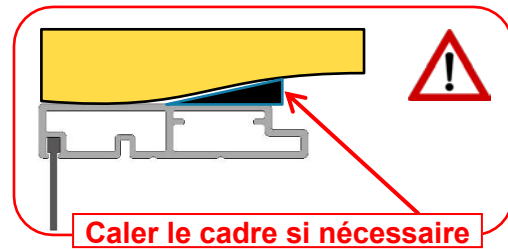
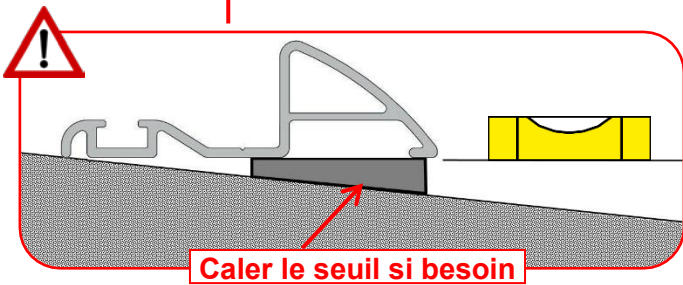
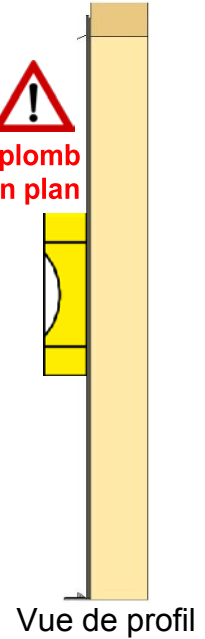

• **Fixer le cadre, le seuil et les platines de liaison :**

Utilisez des fixations (non fournies) adaptées au support

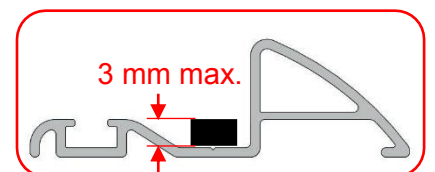
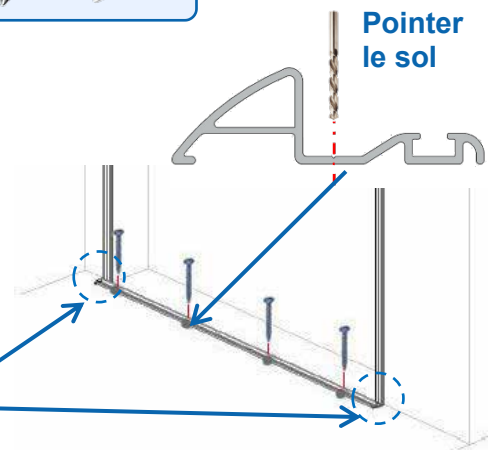
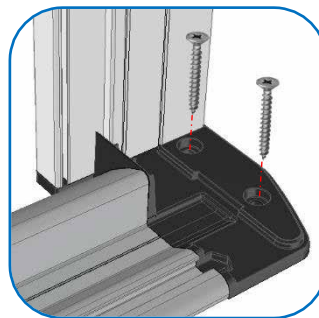
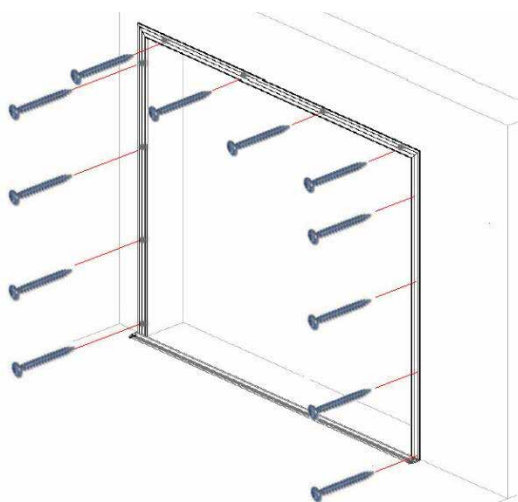
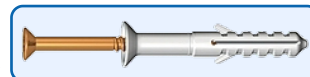

! Les chevilles à frapper ne doivent pas dépasser une hauteur de 3 mm

Cadre de refoulement (Refoulement à gauche représenté)

- Positionner de niveau le 1^{er} profilé de refoulement et le fixer (visserie non fournie)

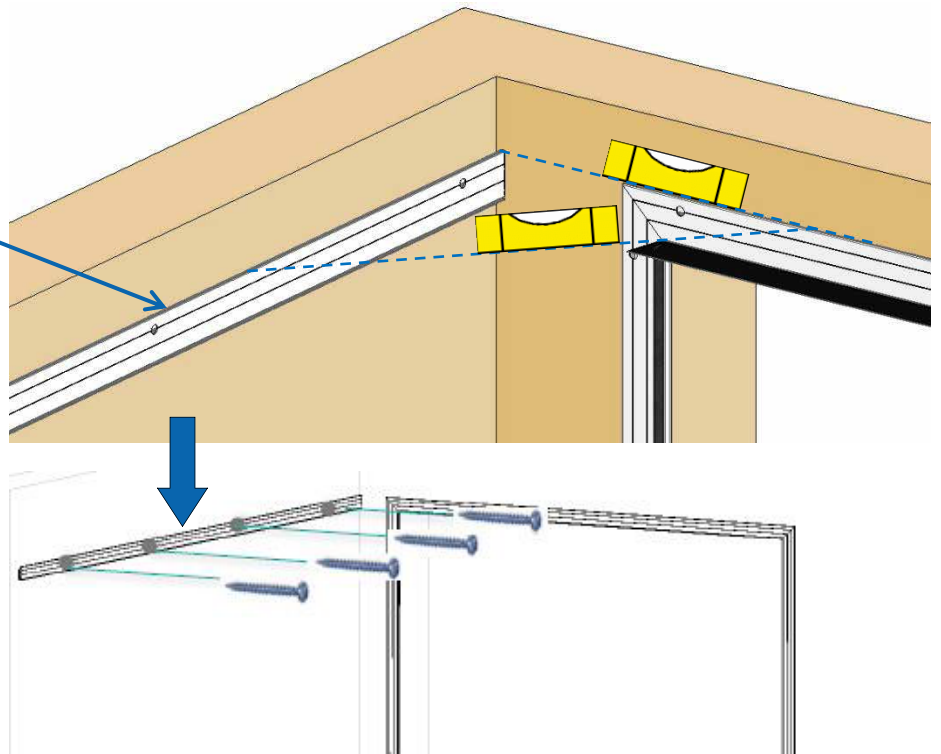
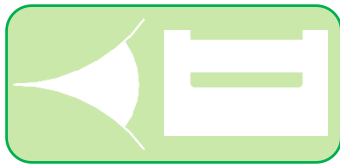

- Si profilé de refoulement en 2 parties, effectuer le montage ci-dessous :

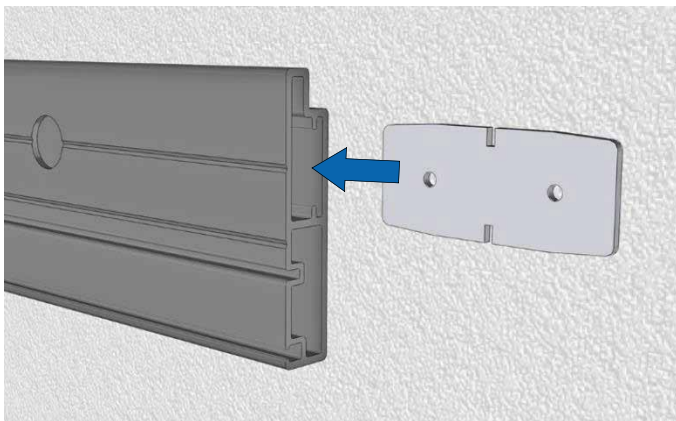

Insérer l'éclisse dans le 2^{ème} profilé

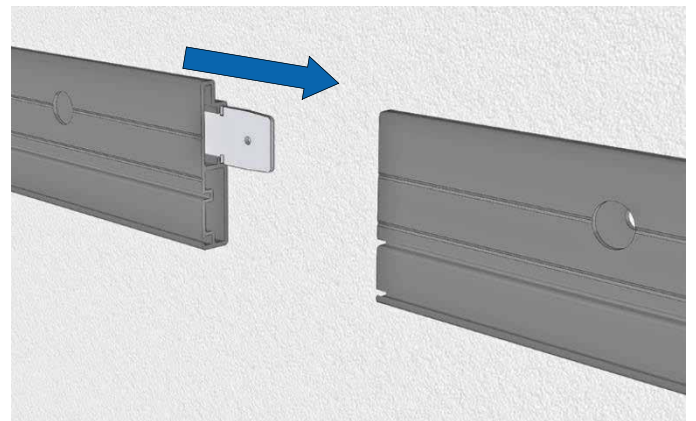

L'assembler avec le 1^{er} profilé

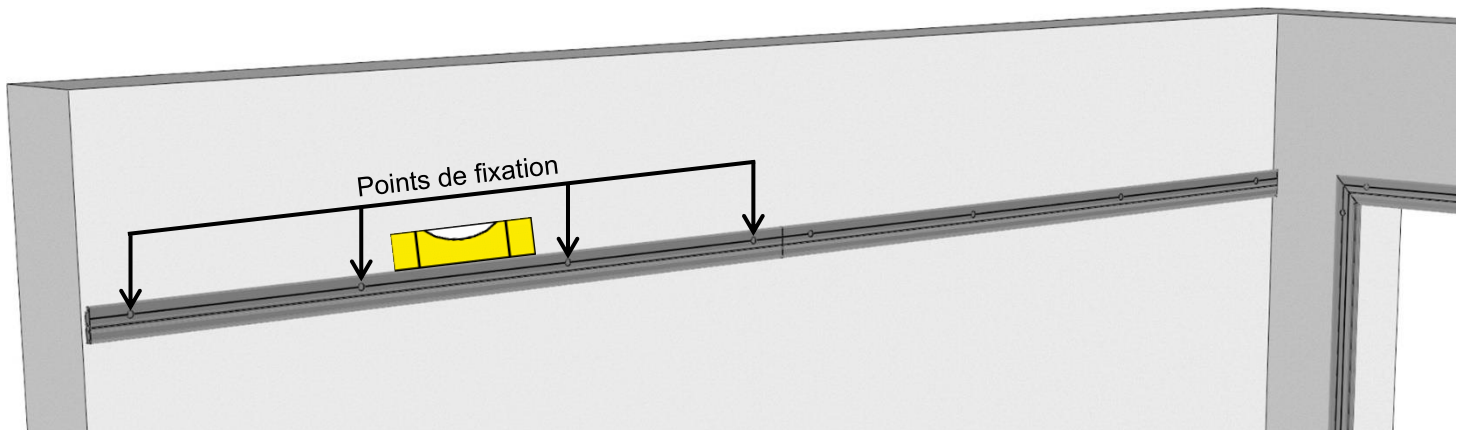

Positionner le 2^{ème} profilé de niveau et le fixer (visserie non fournie)

- **Si Écoinçon Côté Refoulement (ECR) > 400 mm :**
Positionner de niveau le 1^{er} profilé écoinçon et le fixer (visserie non fournie)

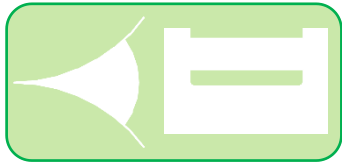

Profilé cadre "écoinçon"



Côté mur

1 **Etiquette de repère**

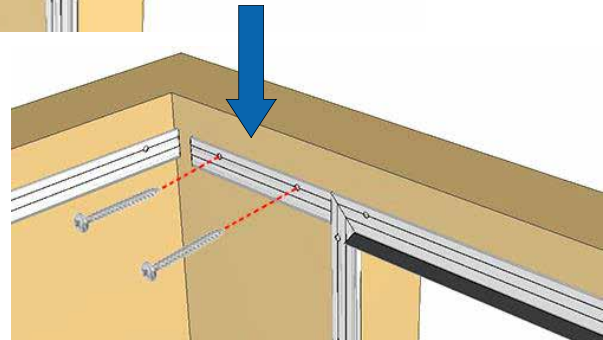
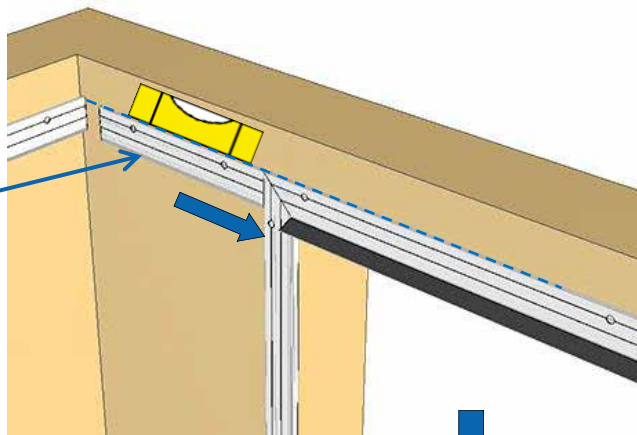

- **Si profilé écoinçon en 2 parties, effectuer le montage ci-dessous :**

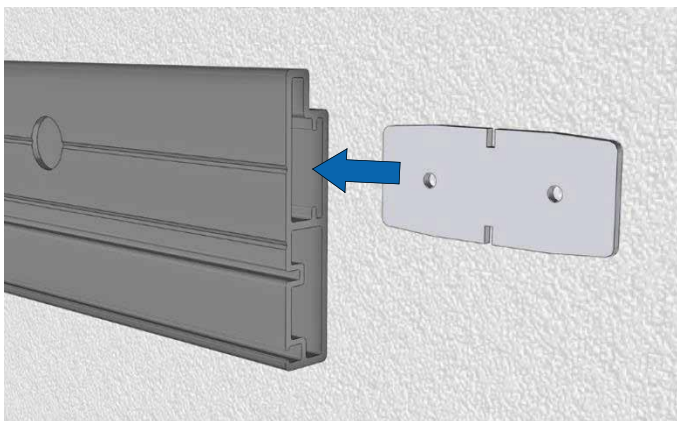

Insérer l'éclisse dans le 2^{ème} profilé

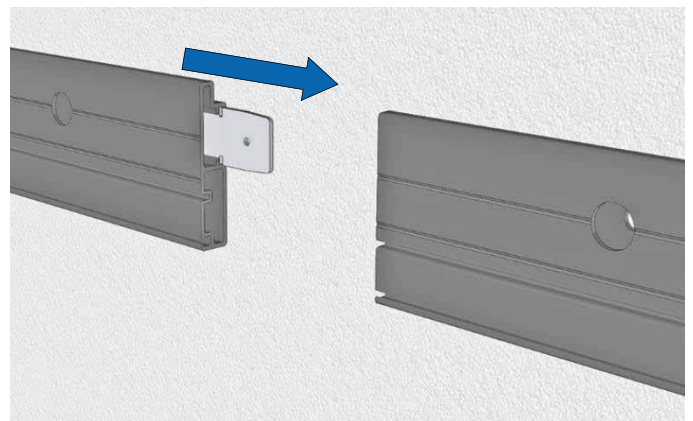

L'assembler avec le 1^{er} profilé

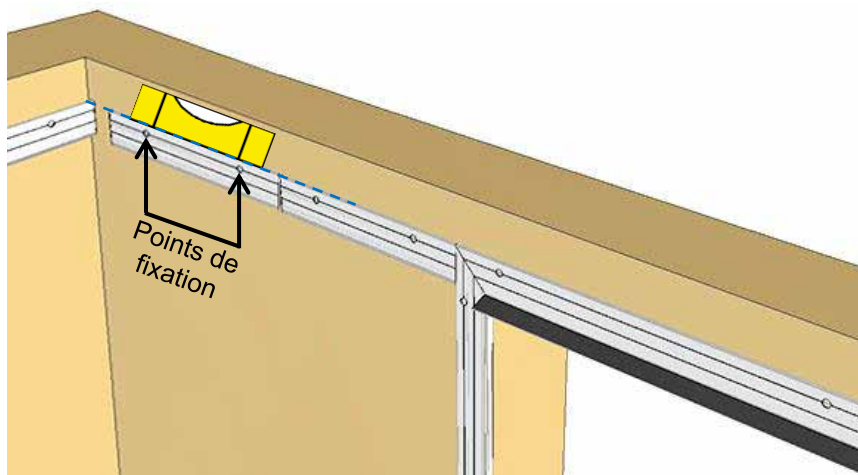

Positionner le 2^{ème} profilé de niveau et le fixer (visserie non fournie)

Rail côté baie (Refoulement à gauche représenté)

Assemblage du "rail de guidage haut" sur le sol

• **Rail en 1 partie :**

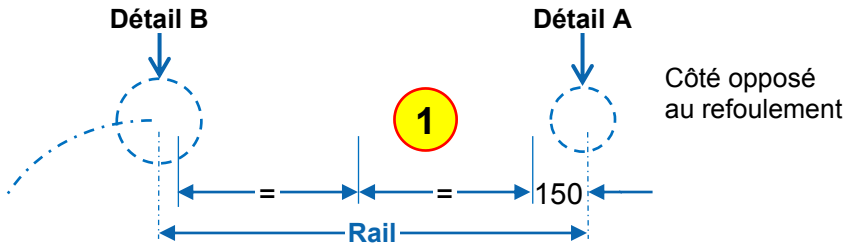

• **Rail en 2 parties :**

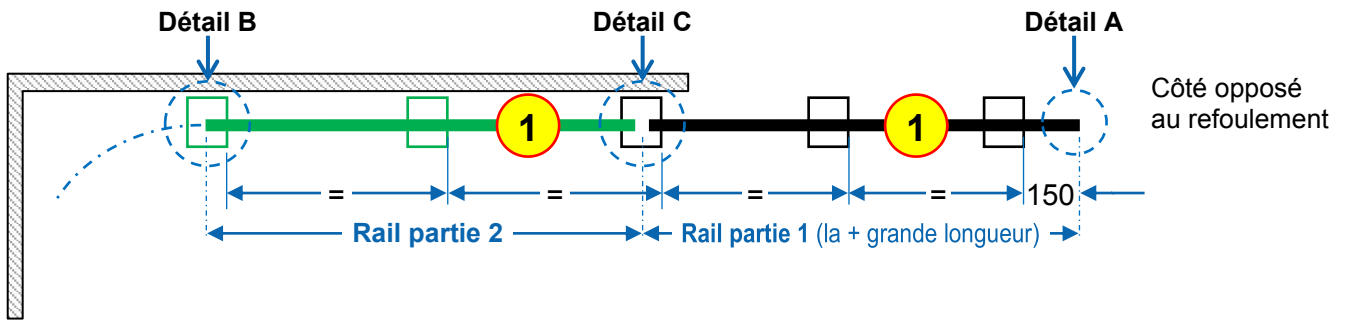

Profilé

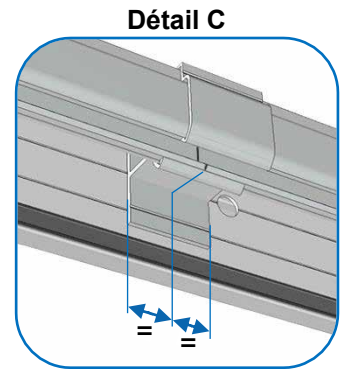
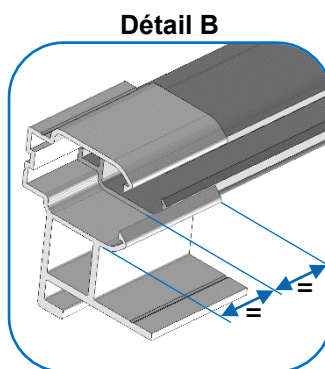
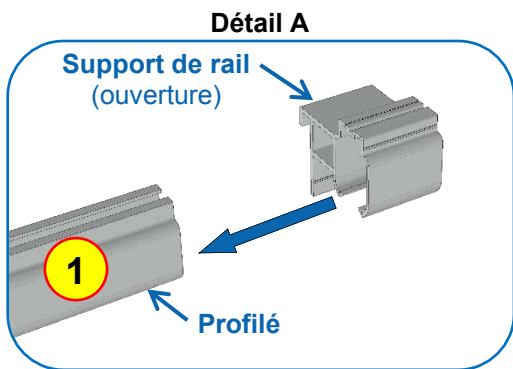
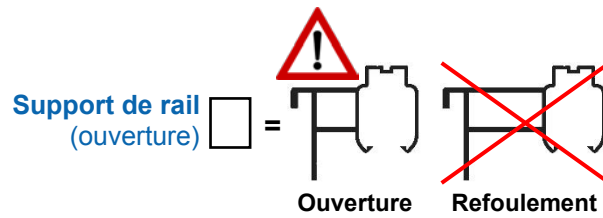
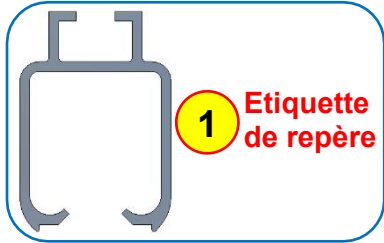

Assemblage et montage du support de cintre

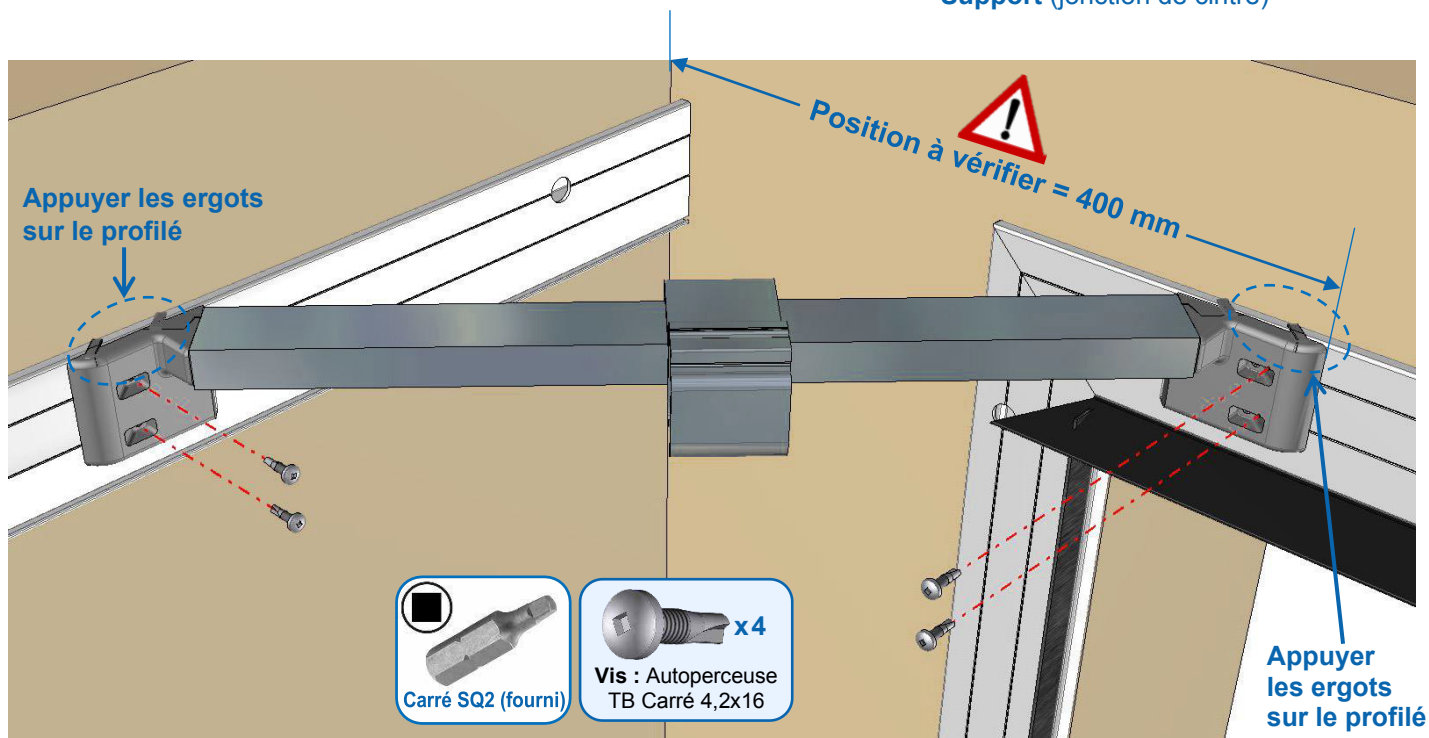
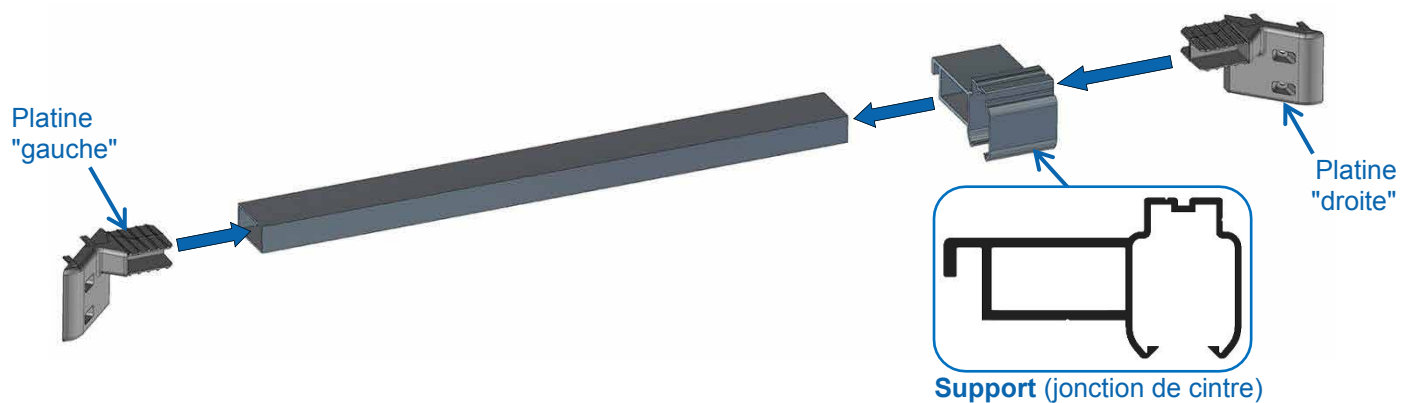

Assemblage du cintre

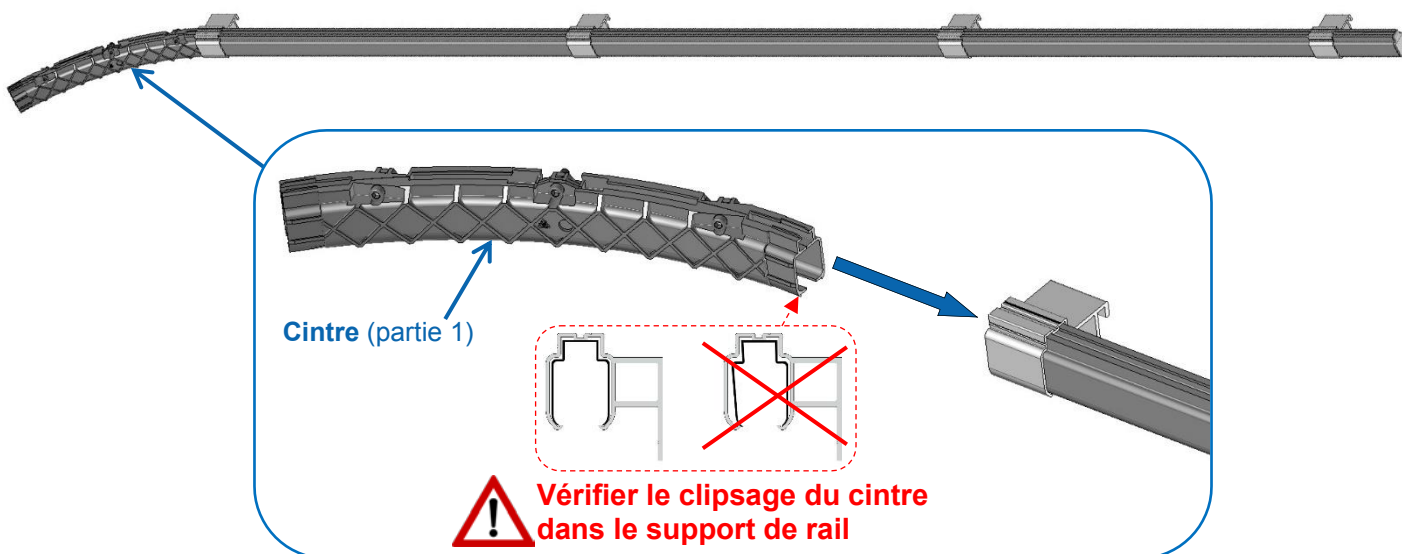

Montage du rail de guidage

• Rail en 1 partie :

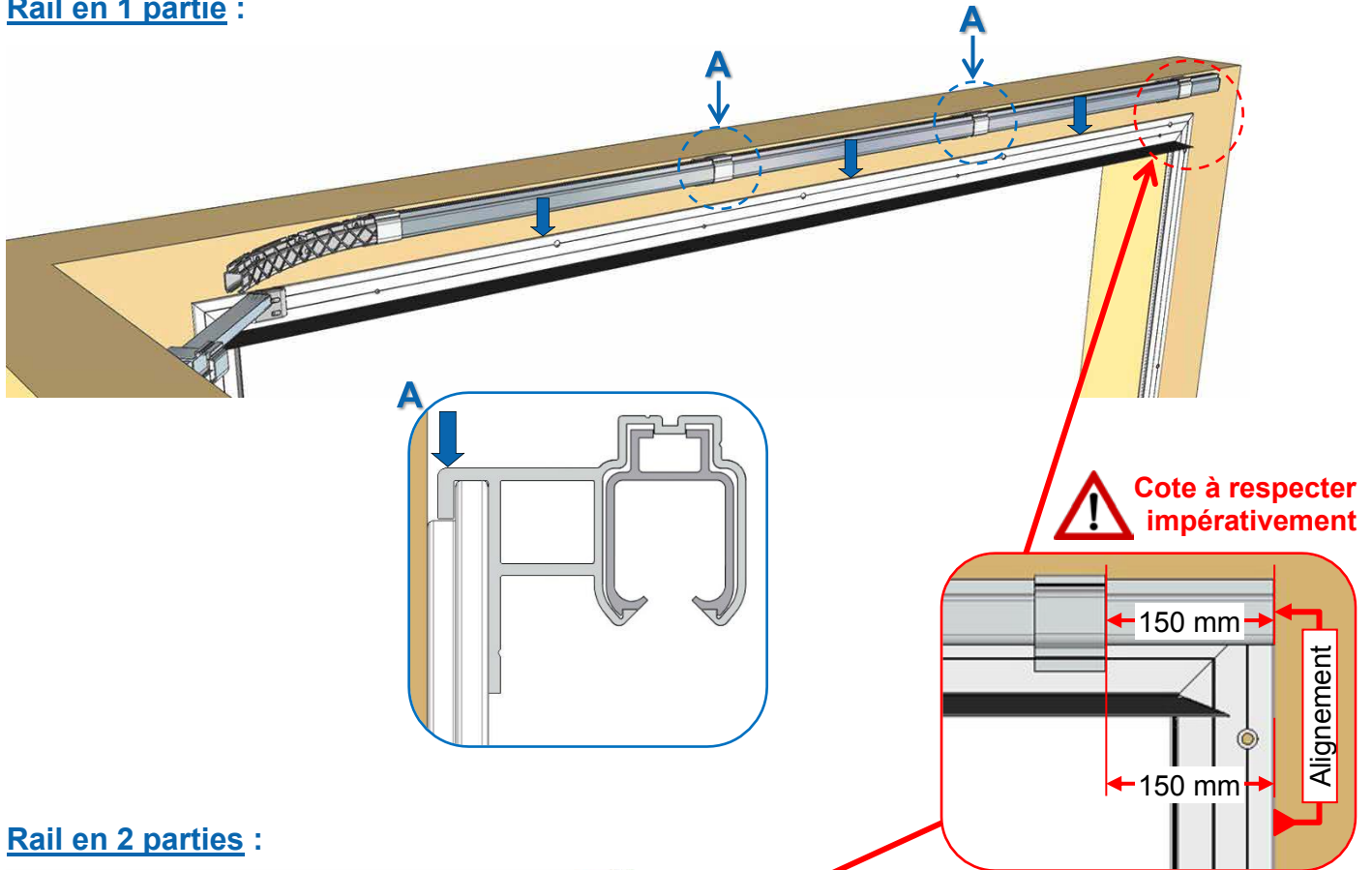

• Rail en 2 parties :

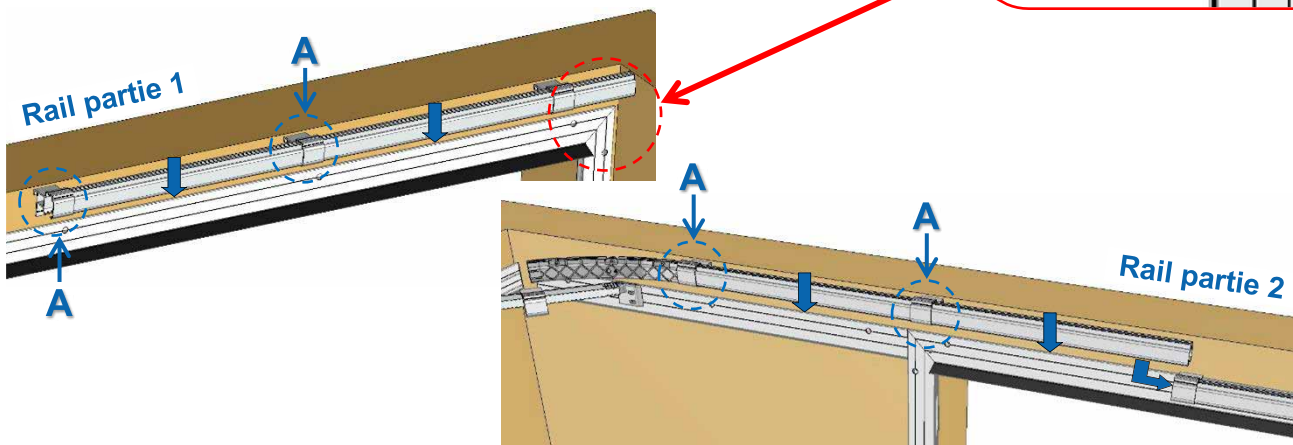

Fixation des supports intermédiaires

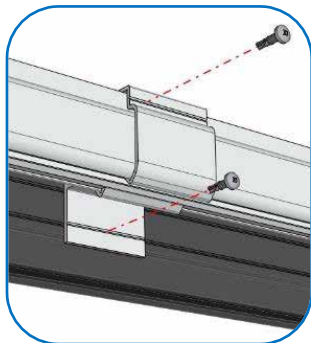

Fixation côté opposé au refolement

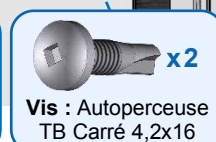
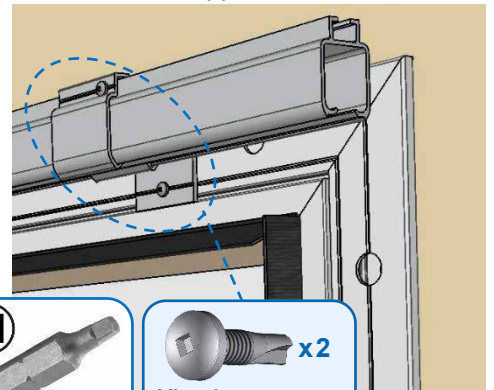

Assemblage du cintre (partie 2)

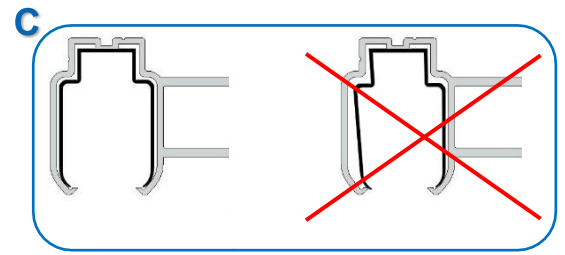
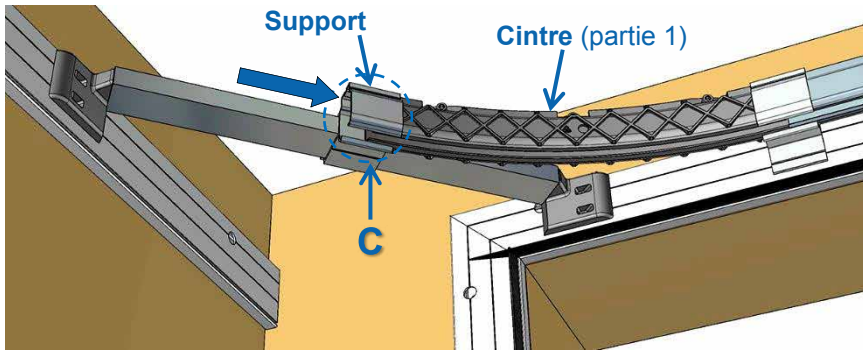

! Vérifier le clipsage du cintre dans les supports de rail

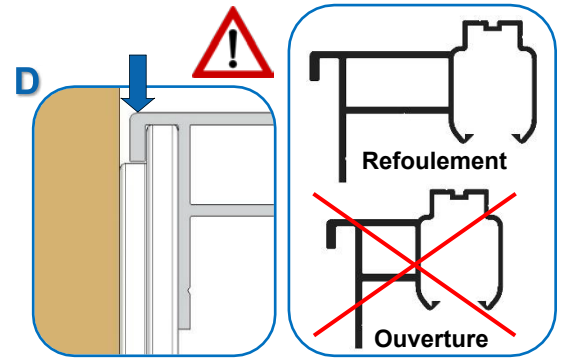
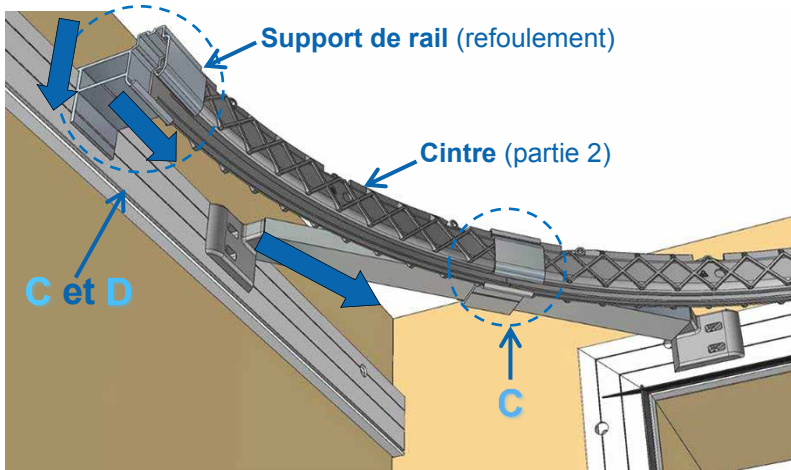

Fixer les 2 supports

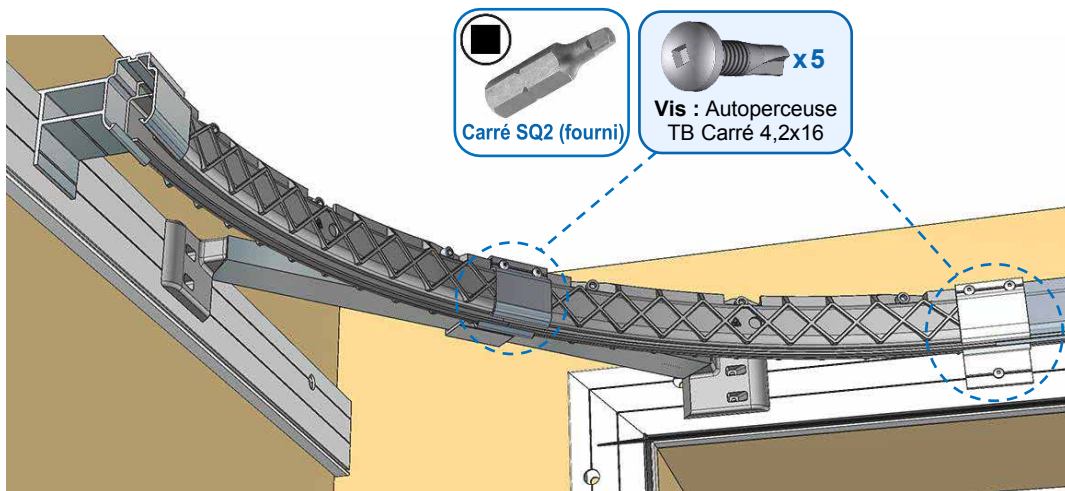

Butée tablier (Refoulement à gauche représenté)

Préparation de la butée

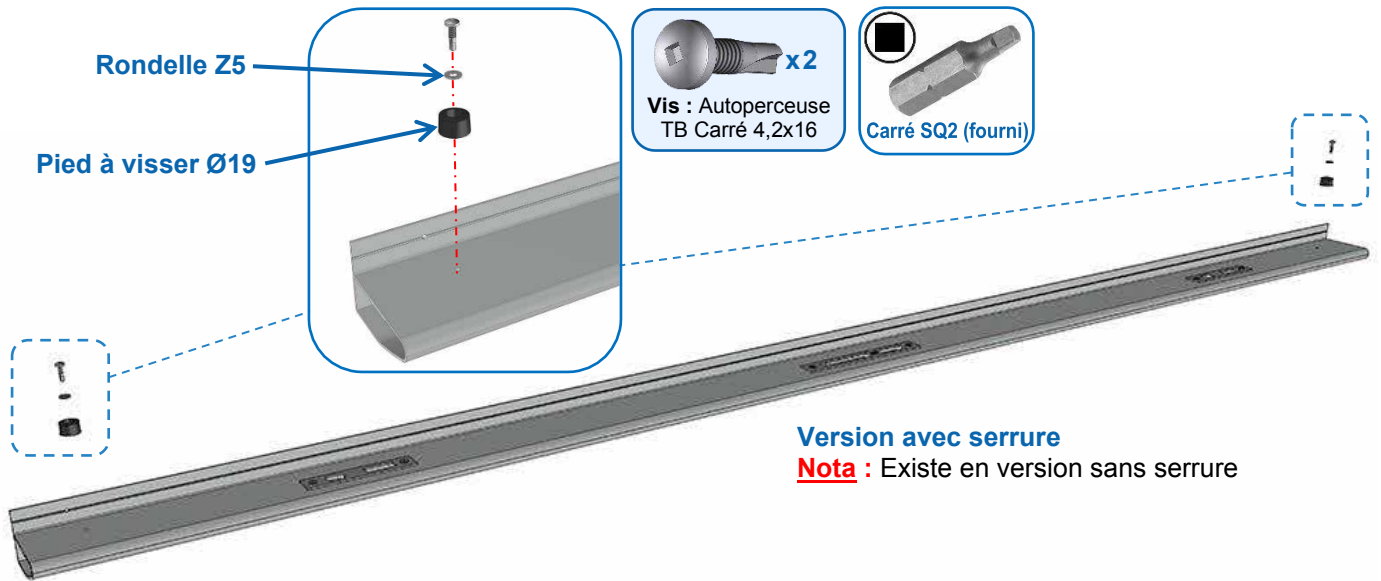

Montage de la butée

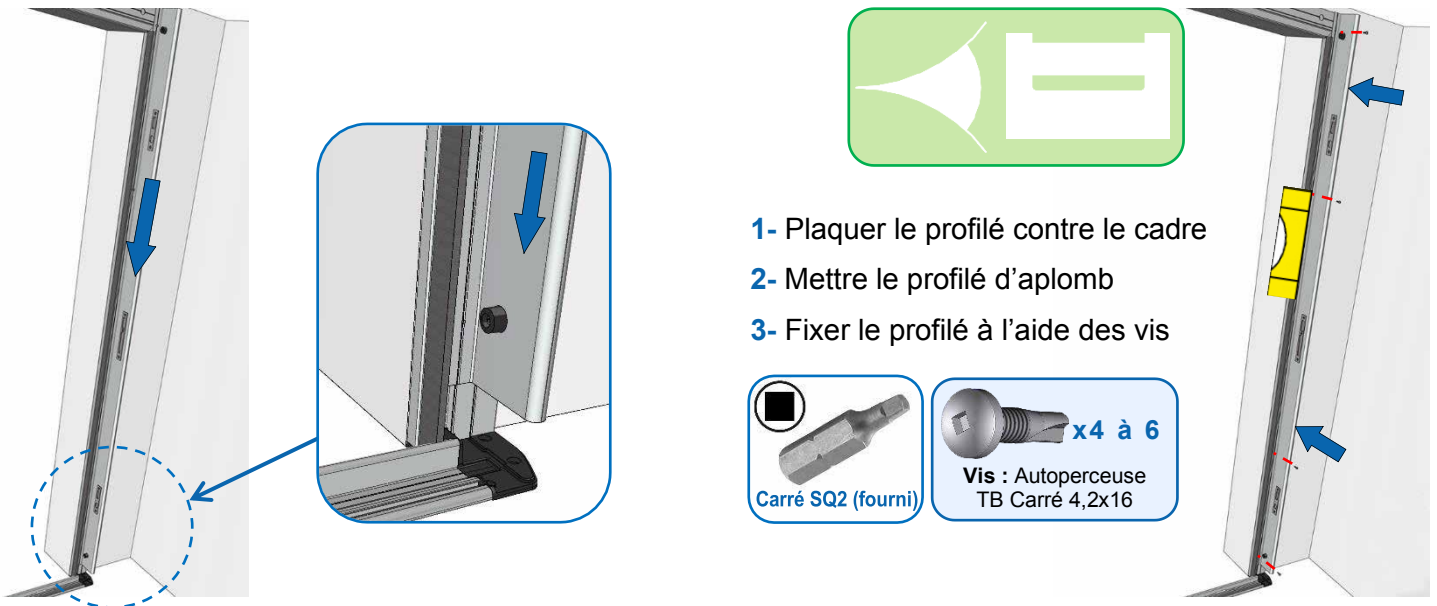

Avant de continuer, vous devez IMPÉRATIVEMENT contrôler :



- 1- Le cadre est parfaitement de niveau, d'aplomb et d'équerre.
- 2- Le cadre doit être parfaitement plan :
Eviter toute "vrille" liée aux imperfections de l'ossature.
- 3- Respectez la position du rail côté opposé au refoulement (cote de 150 mm).
- 4- Le seuil doit être parfaitement plan.

Tablier (Refoulement à gauche représenté)

Vue d'ensemble

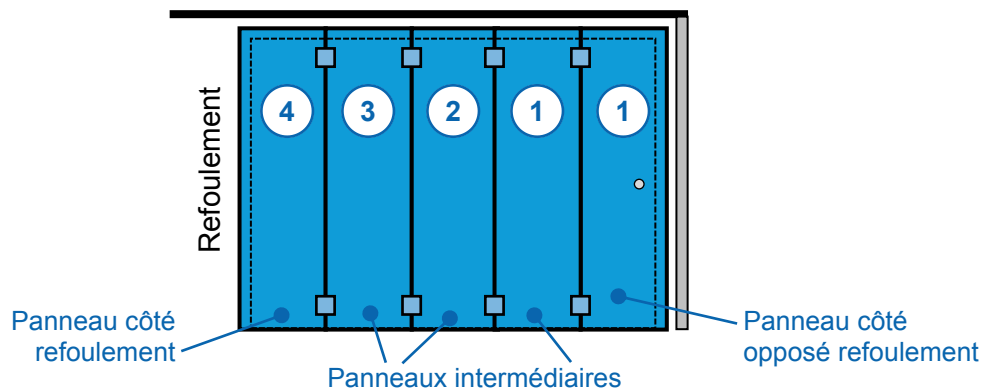

Préparation du panneau côté opposé au refolement

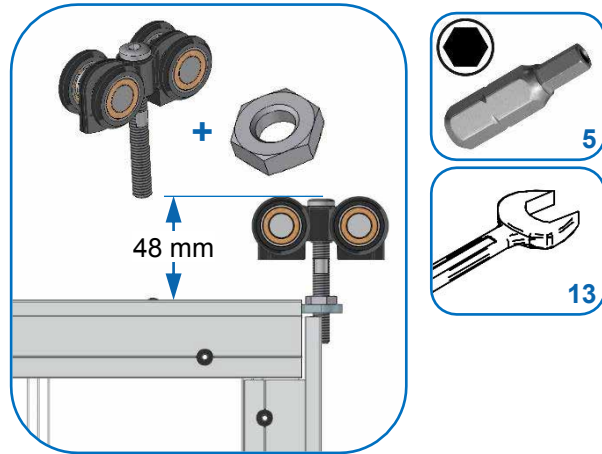
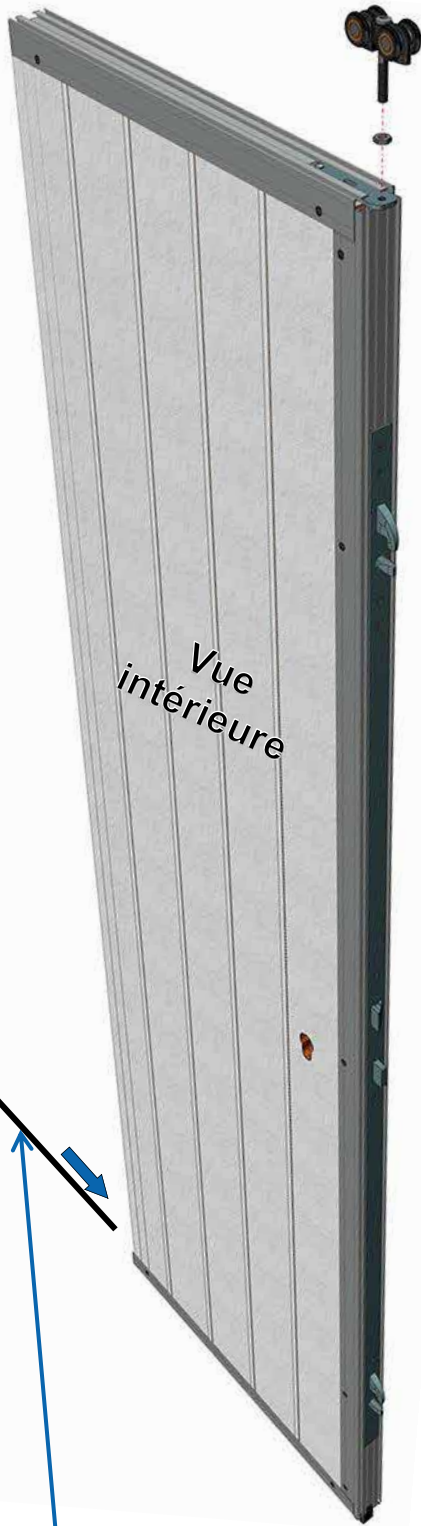

Réglage des chariots

Utiliser l'équerre de contrôle

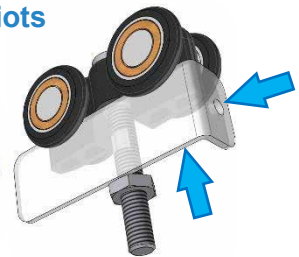
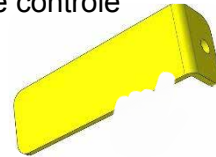

Version avec serrure

Nota : Existe en version sans serrure

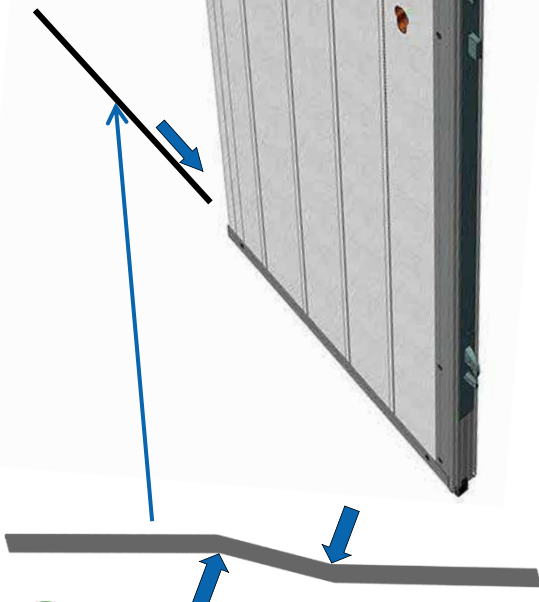

Conseil :

Plier légèrement le joint brosse pour tenir dans le profil.

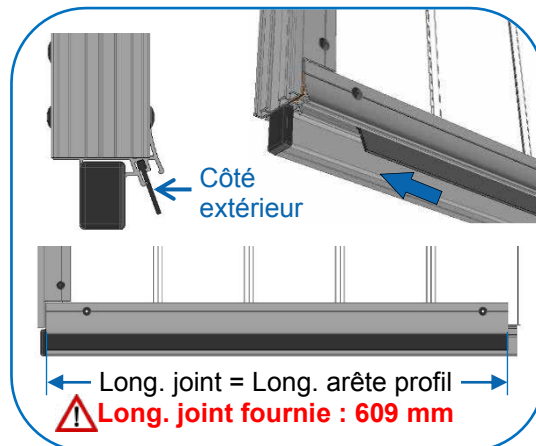

Couper le surplus

Préparation des panneaux intermédiaires

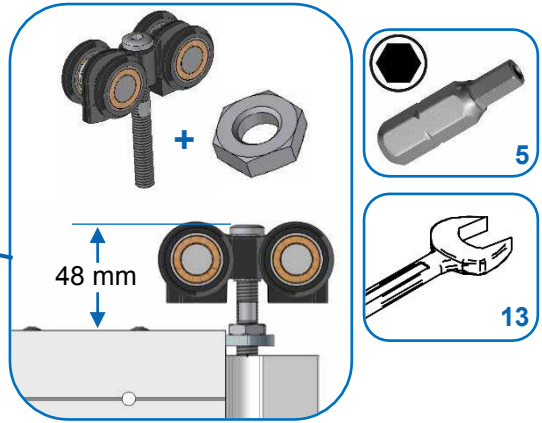
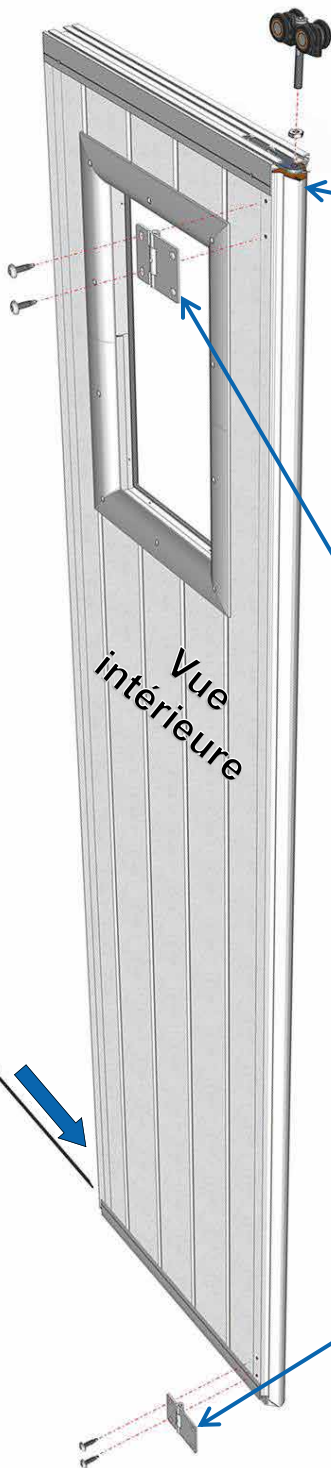

Réglage des chariots
Utiliser l'équerre de contrôle

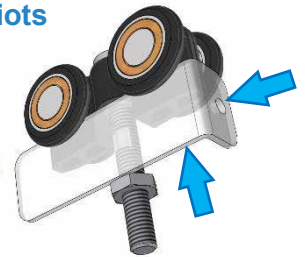
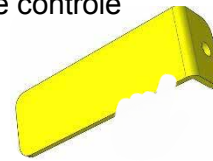

⚠ Nœud de charnière dans la rainure du panneau

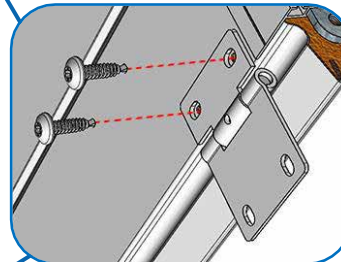

Conseil :
Plier légèrement le joint brosse pour tenir dans le profil.

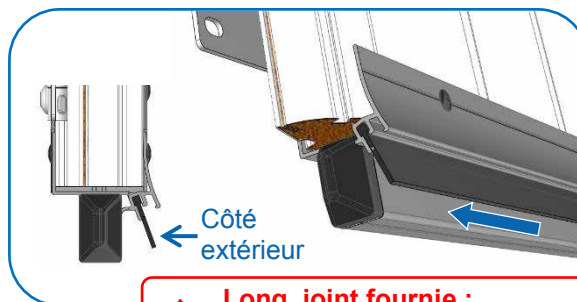

⚠ Long. joint fournie :
499 mm → Panneau 500 mm
609 mm → Panneau 610 mm

Assemblage des panneaux côté opposé au refolement & intermédiaire

• Positionnement & alignement des panneaux :



 **Contact panneaux/charnières**

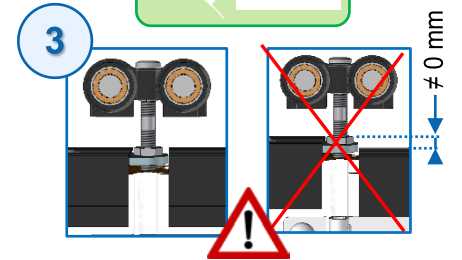
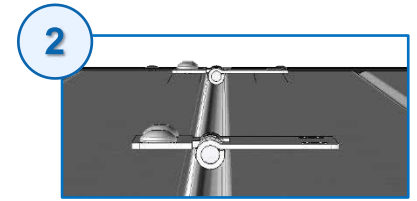

• Fixation des charnières :

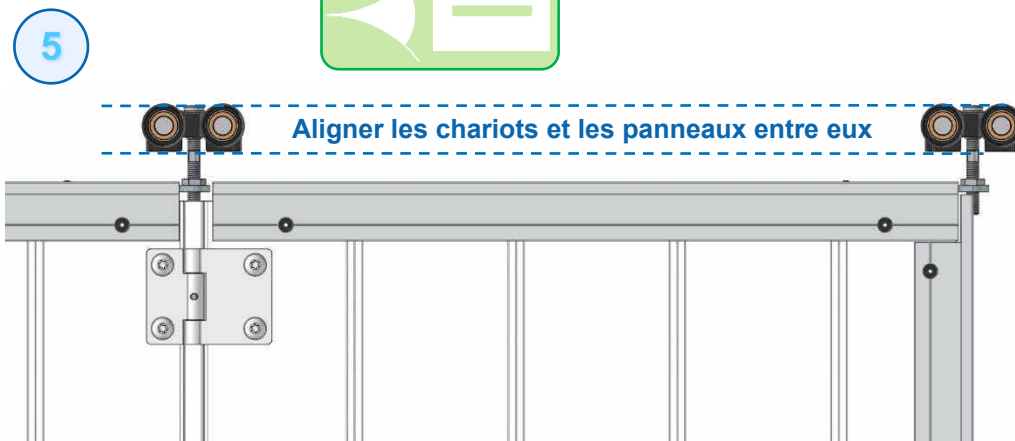
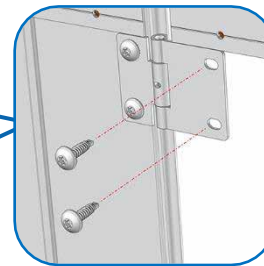
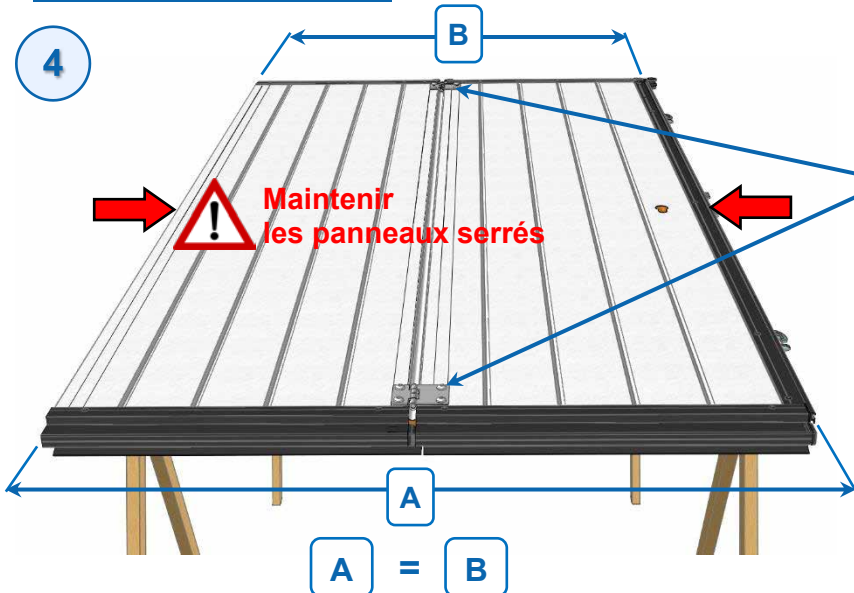

Installation des panneaux côté opposé au refoulement & intermédiaire

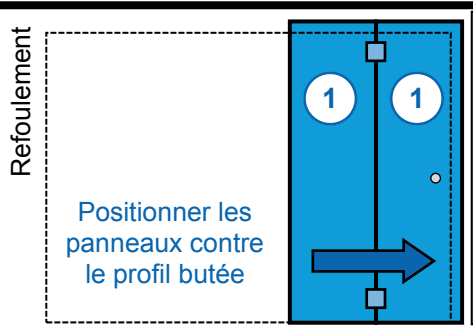
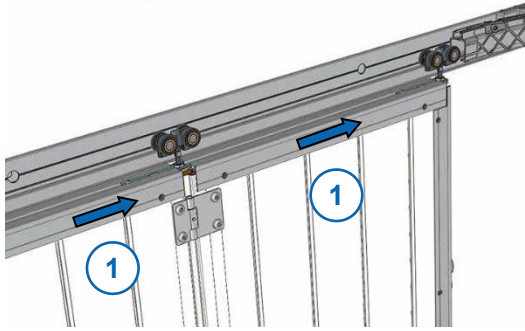

Contrôler le niveau des 2 panneaux

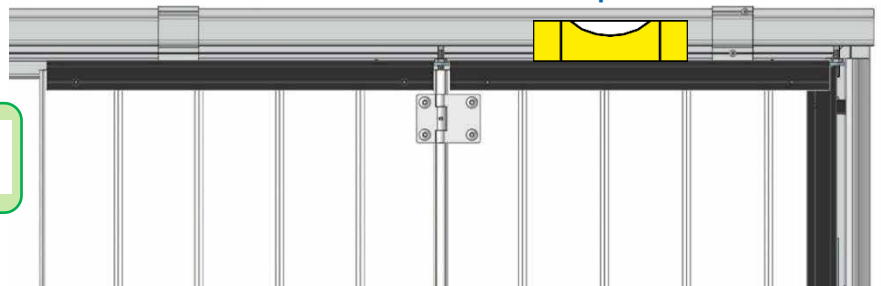

Contrôler la cote entre profil bas/seuil sur toute la longueur du seuil

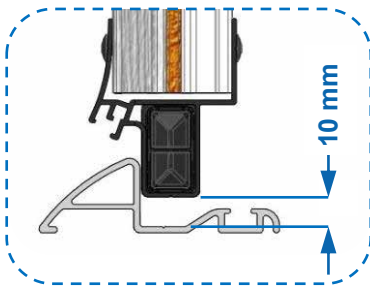

Tolérance : 10 mm +3/-2
Si valeur inférieure à 8 mm,
remonter le tablier d'autant.

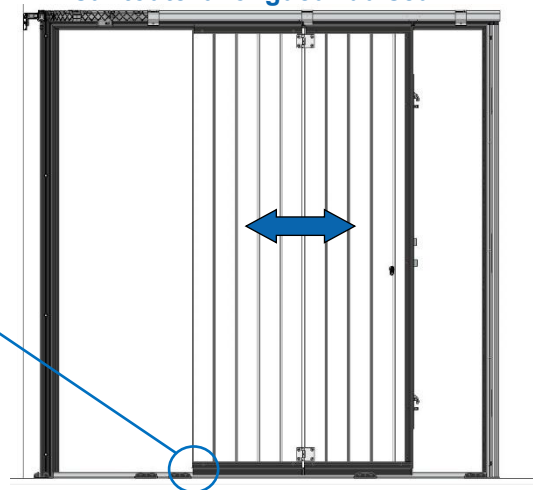

Préparation du panneau côté refolement

Système de placage

Si ECR \geq 225 mm

Glisser la double clame dans le profil vertical

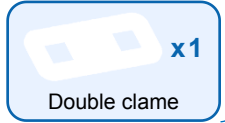

Si HP > 2500 mm

2 systèmes de placage

Régler le support chariot



Trou taraudé à l'extérieur

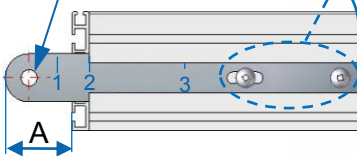

ECR (mm)	Position	A (mm)
$175 \leq \text{ECR} < 500$	2	28
$500 \leq \text{ECR} \leq 585$	3	63
Si ECR > 585 monter le chariot	1	16

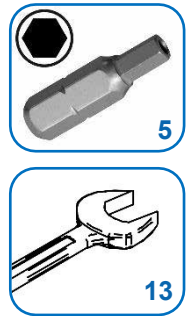
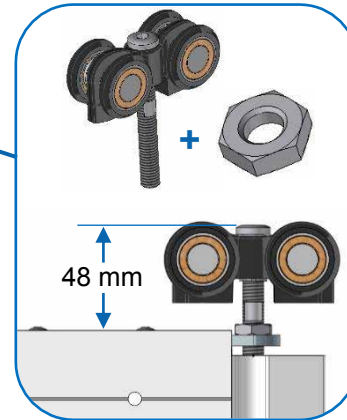

Réglage des chariots

Utiliser l'équerre de contrôle

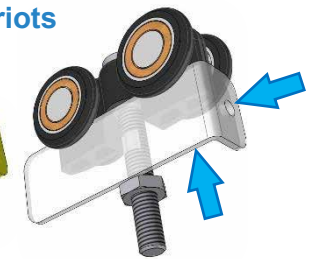
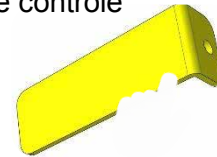

Vue intérieure



Nœud de charnière dans la rainure du panneau

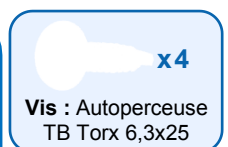
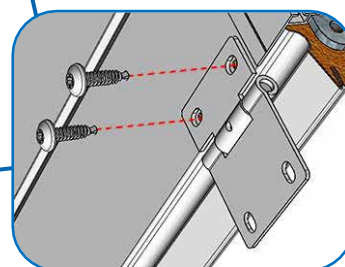

• **Monter les butées caoutchouc : $175 \leq \text{ECR} \leq 585 \text{ mm}$**

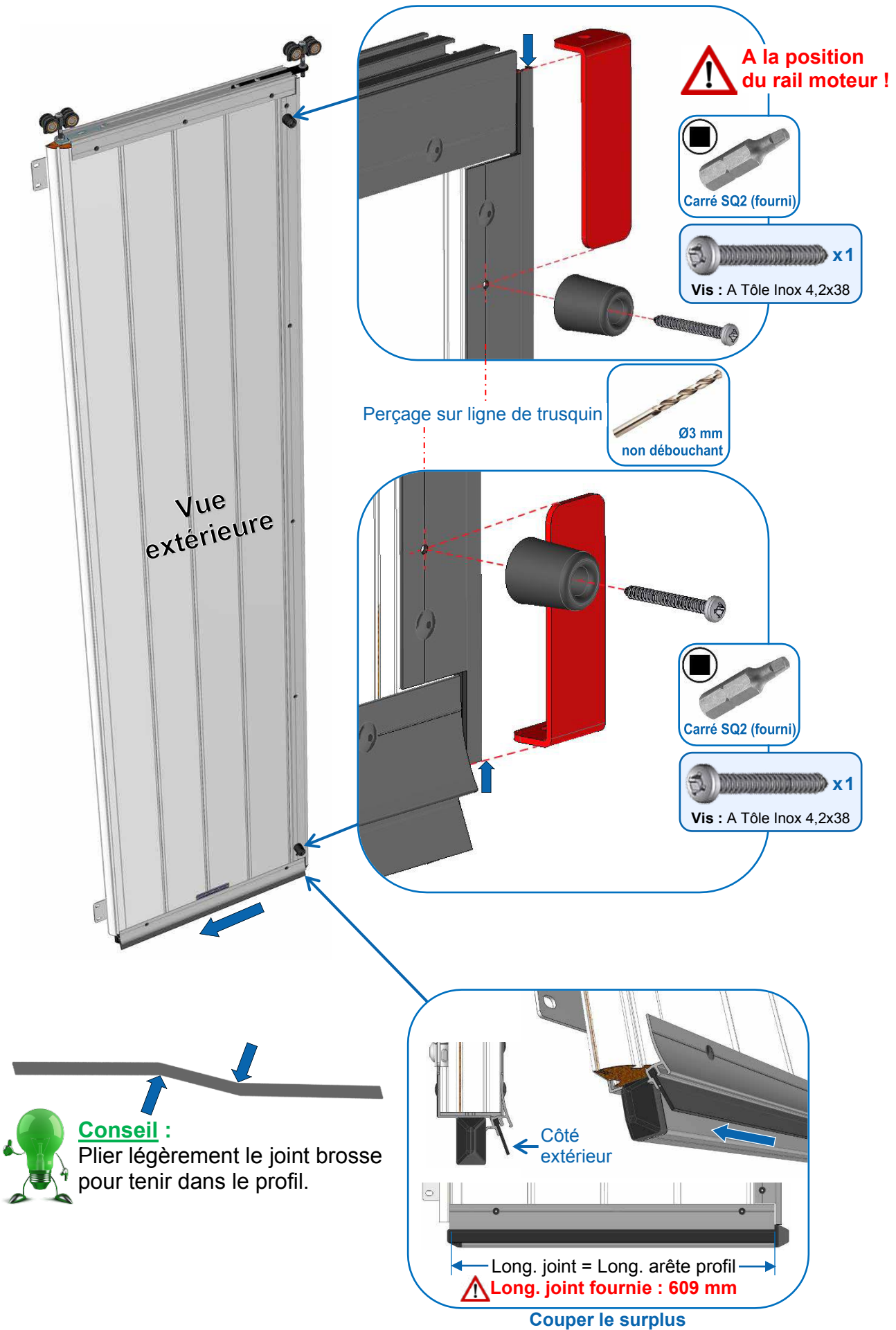

Installation des panneaux intermédiaires par 2 ou avec panneau côté refolement

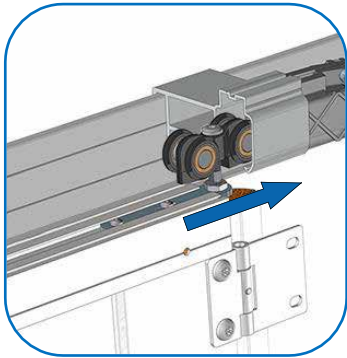

Positionner les panneaux dans la baie suivant l'ordre de montage

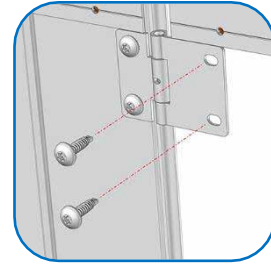
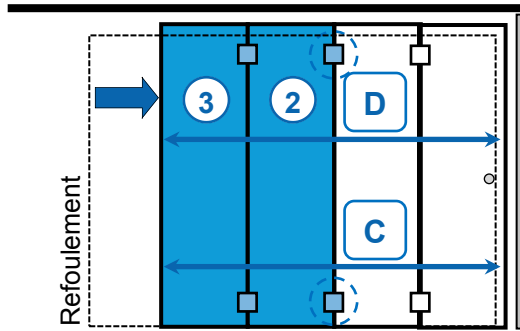

x4
 Vis : Autoperceuse TB Torx 6,3x25
 30

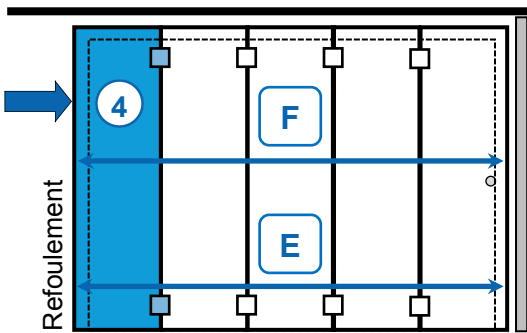
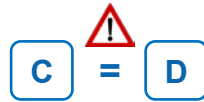

Reprendre les étapes ci-dessus pour le panneau "côté refolement"

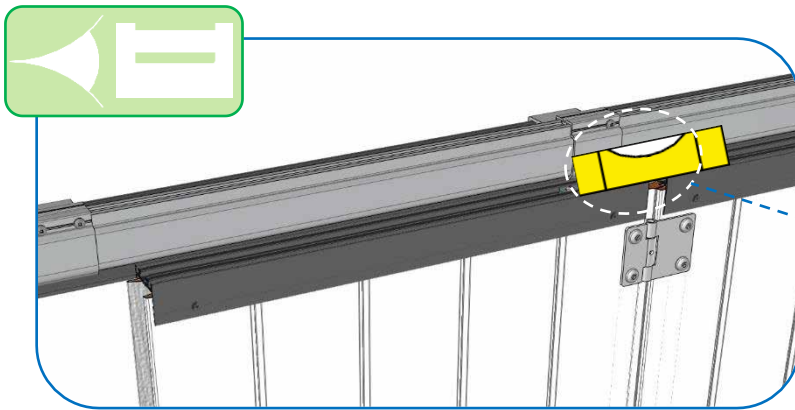
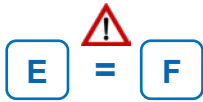

Réglage du chariot

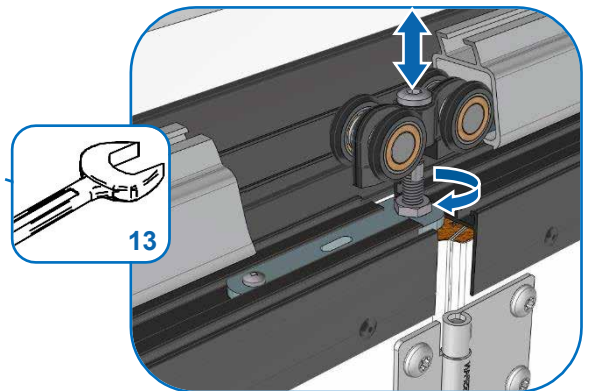

Contrôler la cote entre profil bas/seuil sur toute la longueur du seuil

Tolérance : 10 mm +3/-2
 Si valeur inférieure à 8 mm, remonter le tablier d'autant.

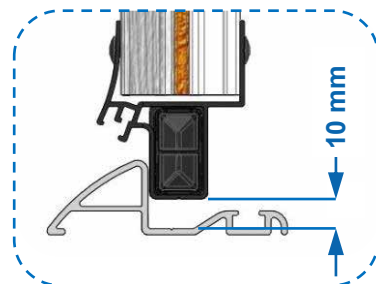

Contrôler la position du tablier

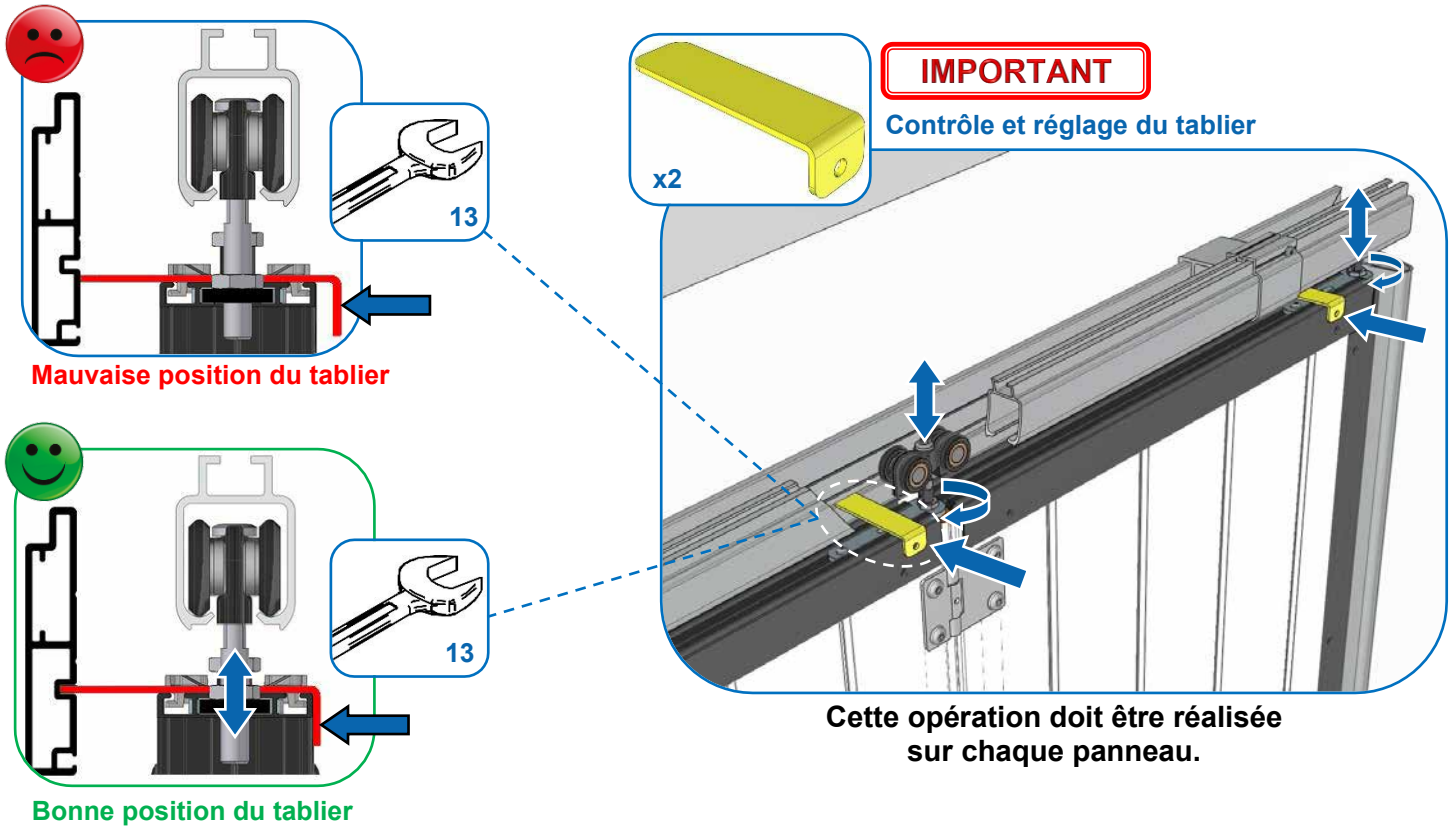

Contrôler le niveau sur tout le tablier

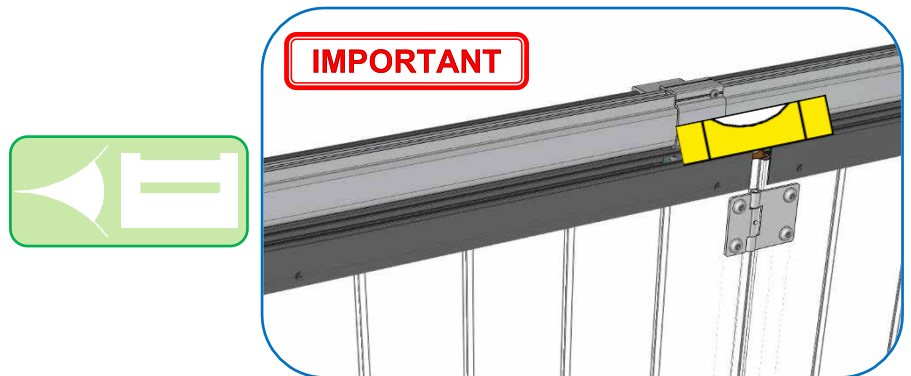

Contrôler le parallélisme

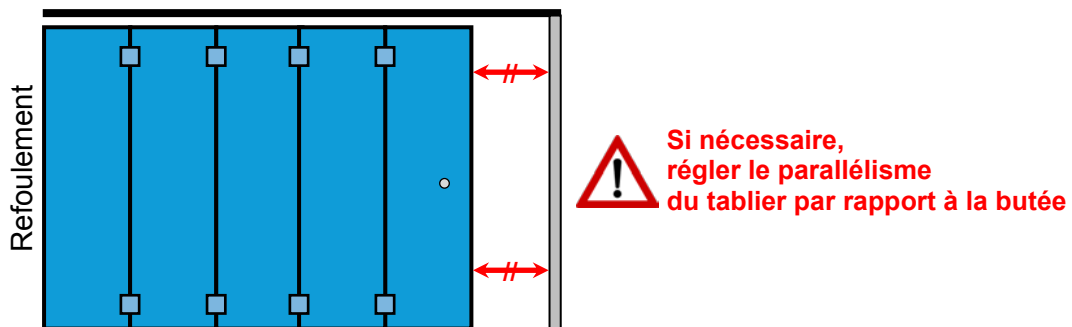

Assemblage du "rail de guidage haut" sur le sol

• **Rail en 1 partie :**

OU

• **Rail en 2 parties :**

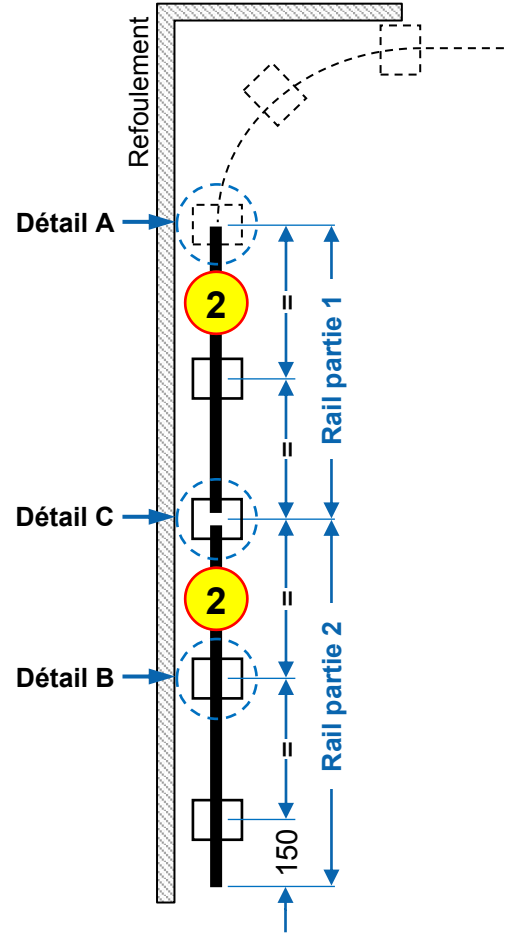
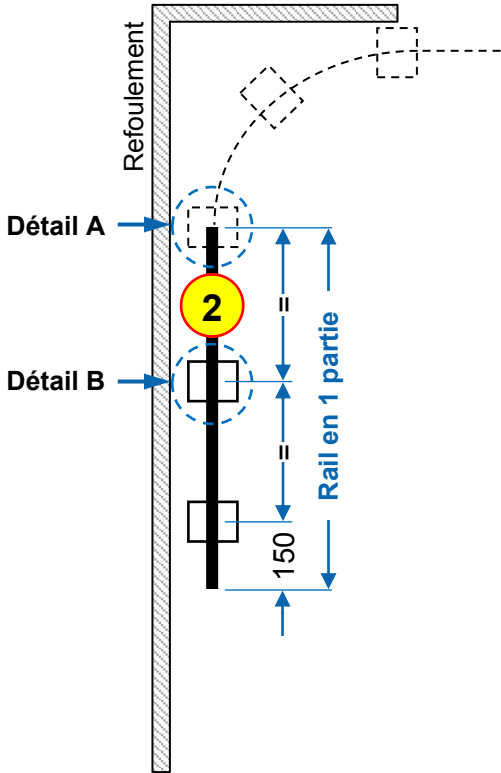

Profilé

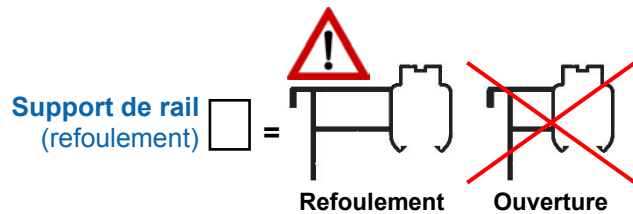
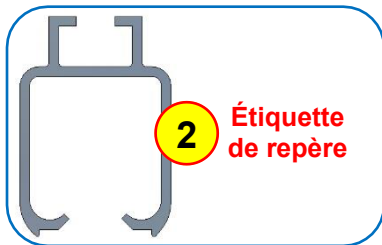

Détail A

Détail B

Détail C

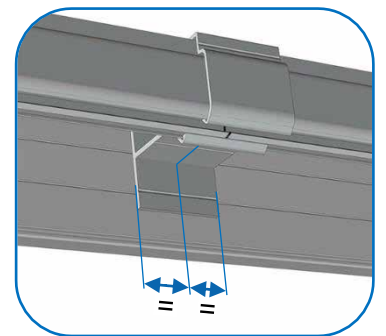
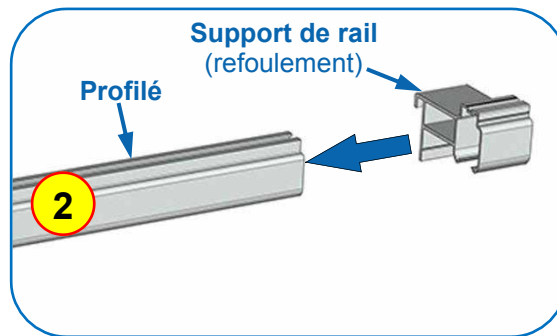
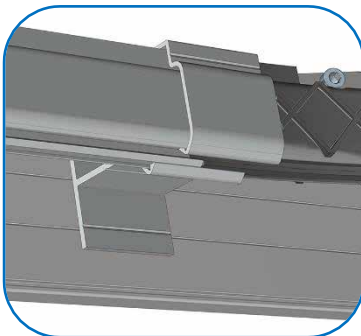

Montage du rail de guidage

• Rail en 1 ou 2 parties :

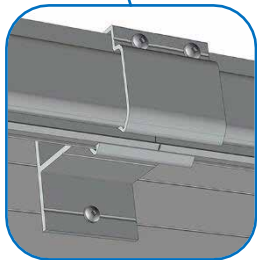
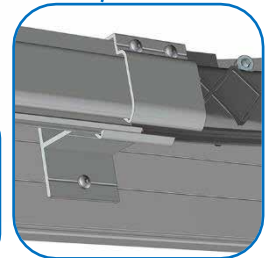
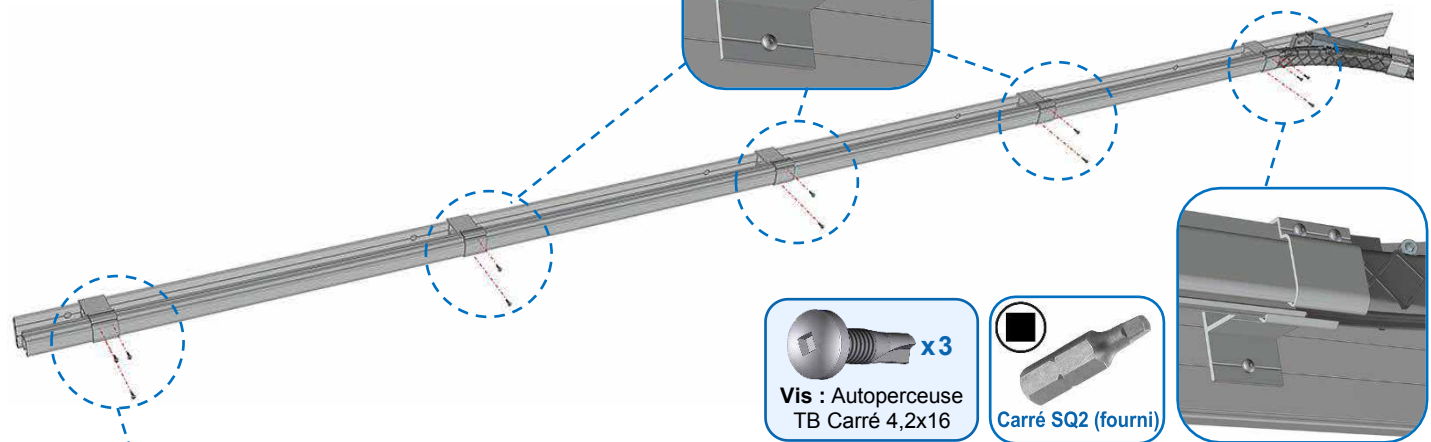
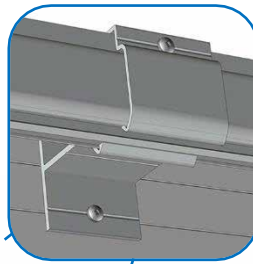
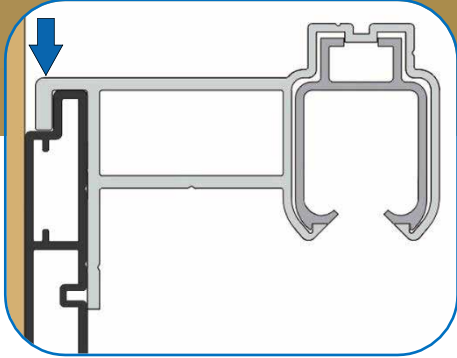
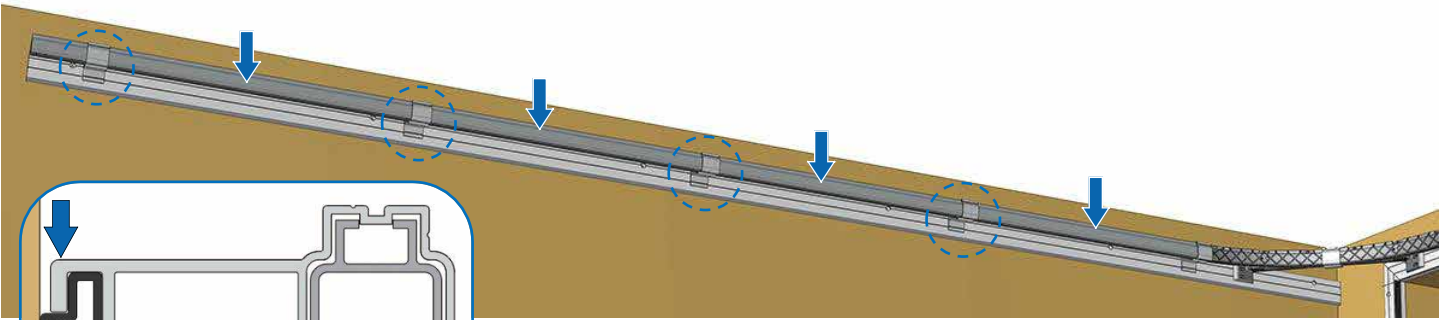

Liaison de rail

Les différents équipements côté refolement

3 cas possibles (Refolement à gauche représenté)

- **Bras multiposition** : $175 \text{ mm} \leq \text{ECR}^* \leq 585 \text{ mm}$ (détail du montage sur les pages suivantes).



- **Rallonge** : $585 \text{ mm} < \text{ECR}^* \leq 1000 \text{ mm}$ (détail du montage sur les pages suivantes).



- **Pas d'équipement** : $\text{ECR}^* > 1000 \text{ mm}$ (détail sur les pages suivantes).

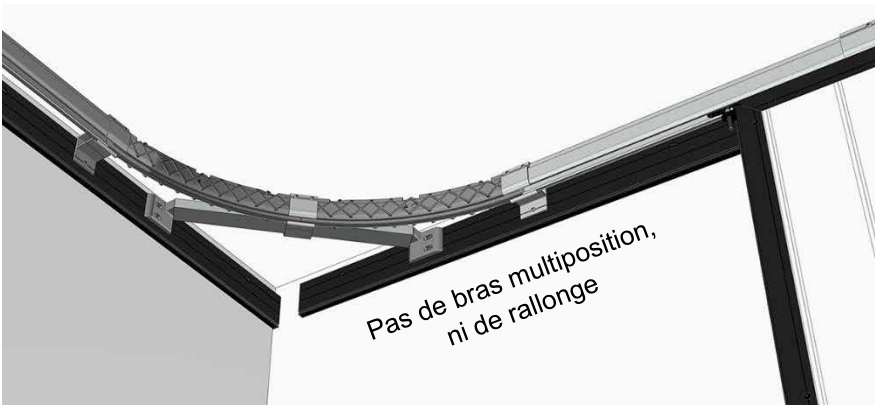

* ECR = Ecoinçon Côté Refolement

Bras multiposition pour écoinçon : $175 \leq ECR \leq 585$ mm

Montage du bras

- Glisser les 2 chariots dans le rail de guidage :

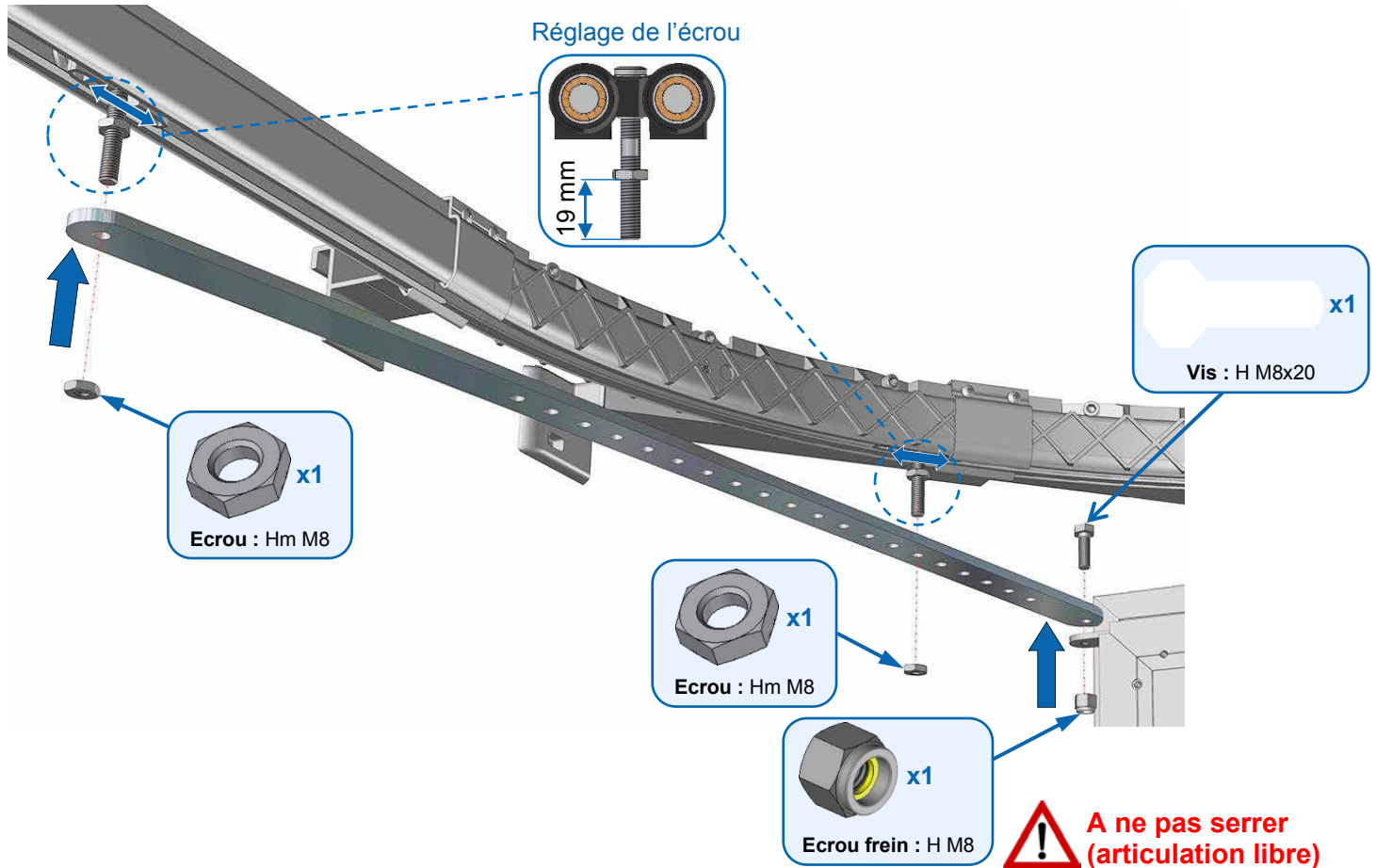

- Monter le bras en fonction de l'écoinçon (Valeur théorique : A ajuster sur chantier)

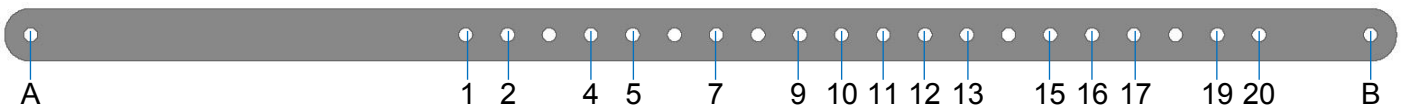

Extrémités du bras	Bras entier							Bras recoupé								
	A et B							B et 2	B et 4	B et 4	B et 1	B et 5	B et 9	B et 11	B et 13	B et 16
* N° du trou	7	9	10	12	15	17	19	19	18	19	20	20	20	20	20	20
Ecoinçon (mm)	175	200	225	250	300	350	400	415	425	450	500	515	535	550	560	585

* Dans le cas d'un écoinçon tombant entre 2 numéros de trous, prendre le numéro du trou inférieur.

Rallonge pour écoinçon : $585 < ECR \leq 1000$ mm

Préparation de la rallonge

IMPORTANT : Ecrou H bas à embase M8

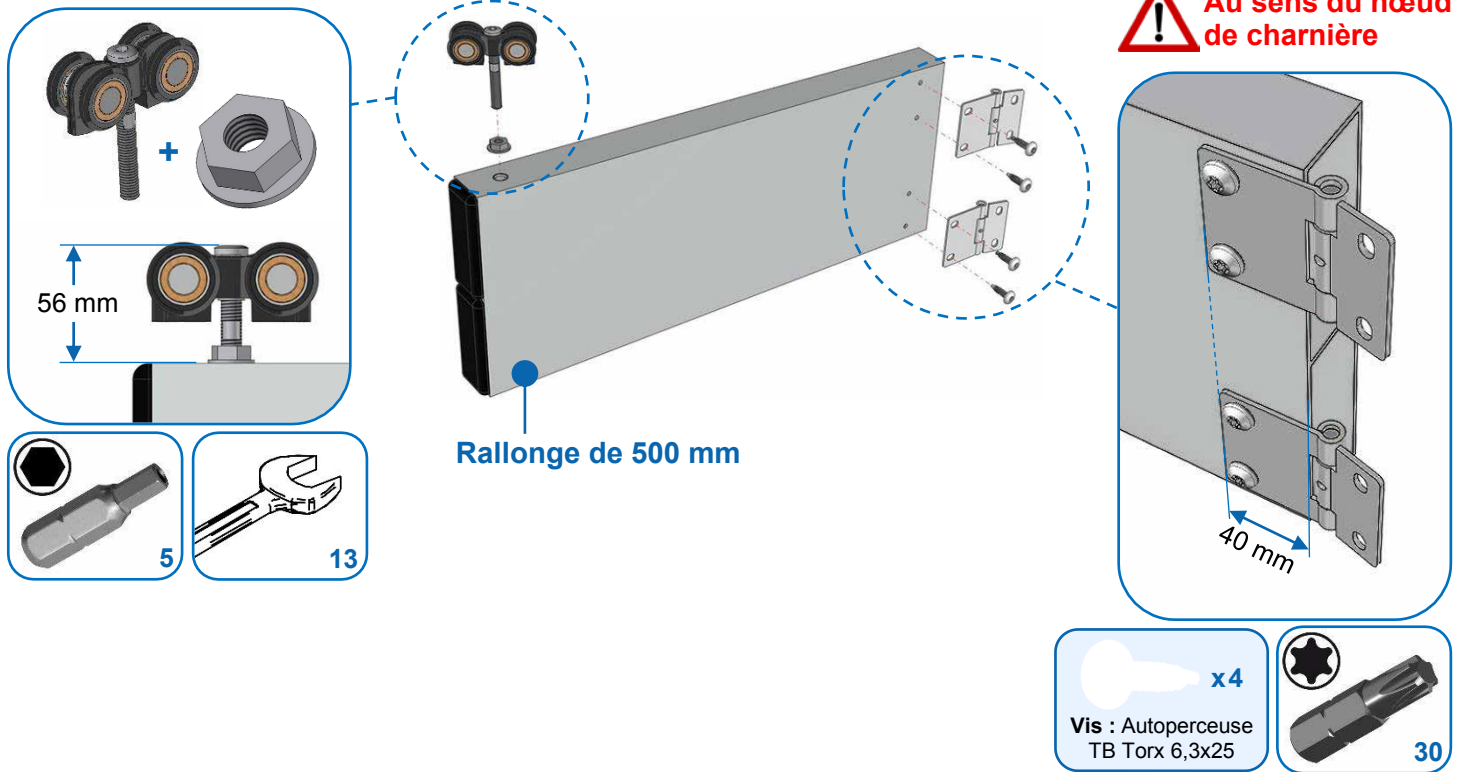

Montage de la rallonge

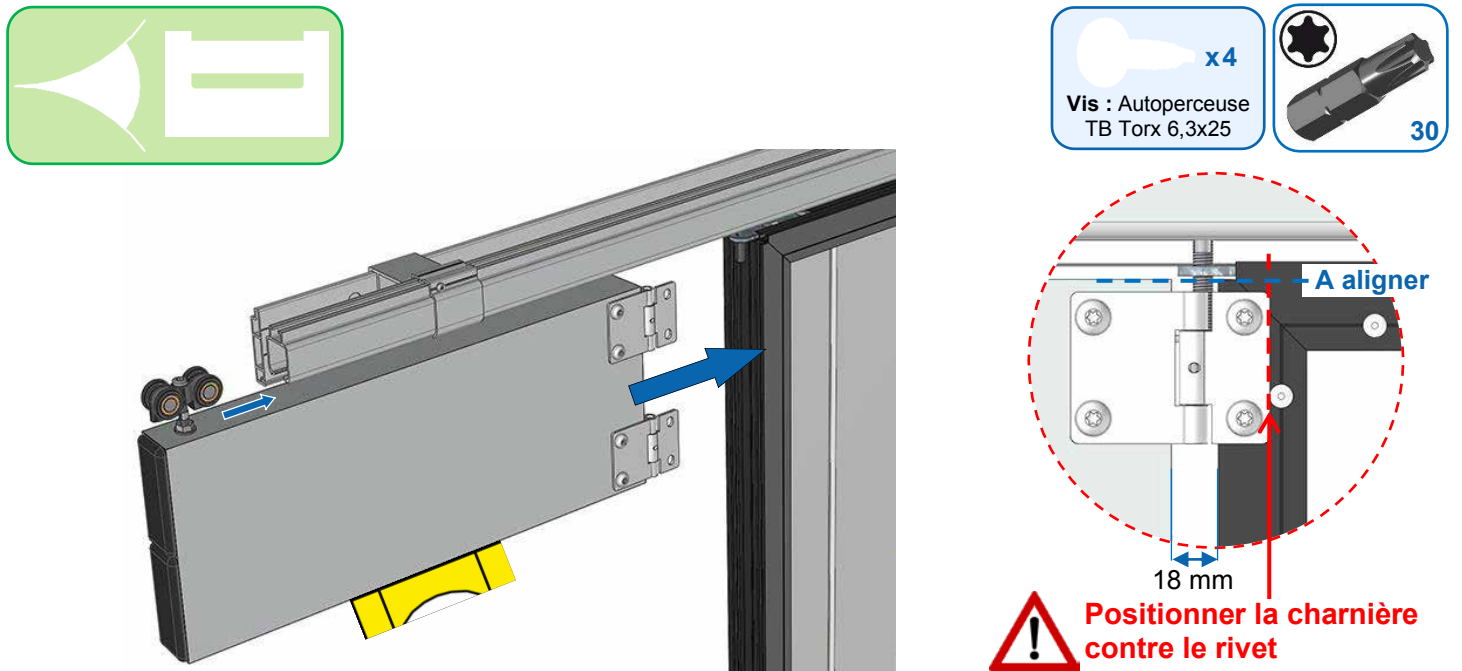

Pas d'équipement pour écoinçon : ECR > 1000 mm



Pas de bras multiposition

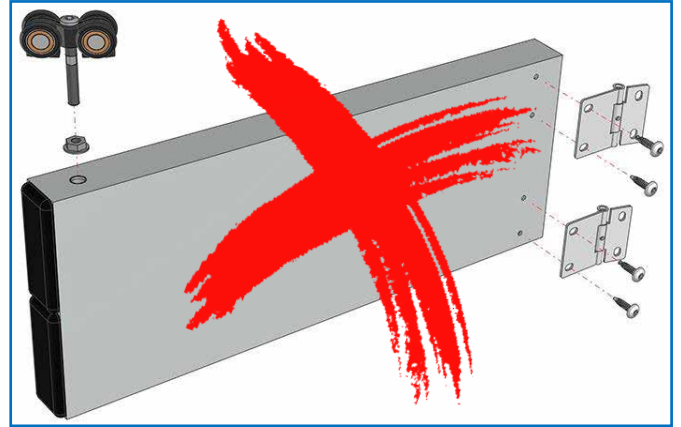

Pas de rallonge

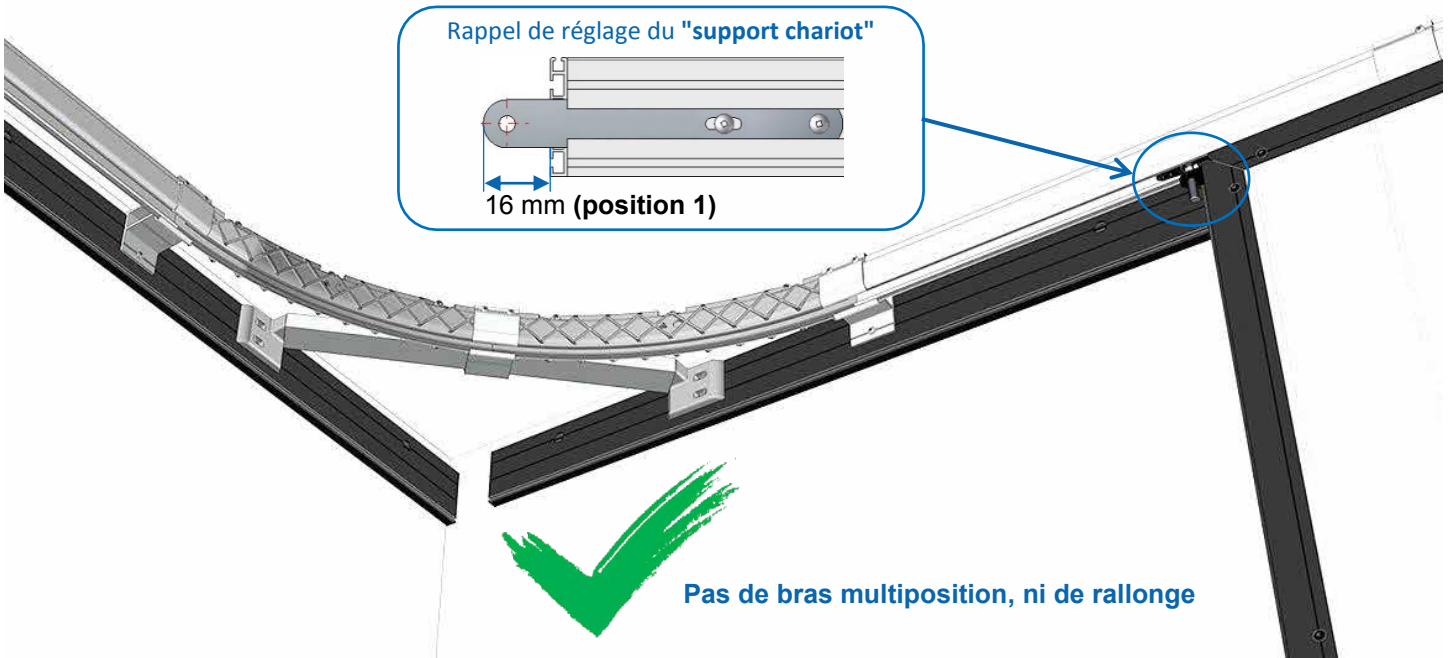

Rappel de réglage du "support chariot"

16 mm (position 1)

Pas de bras multiposition, ni de rallonge

Finitions pour tous les types d'écoinçons

Montage de la butée de fin de course

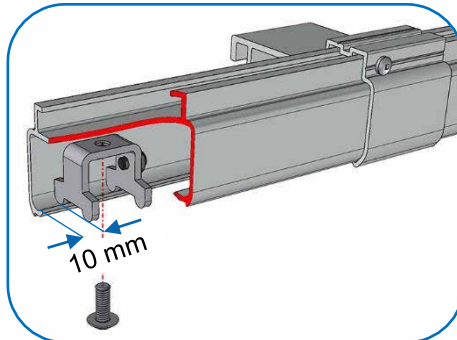
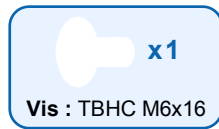

Réglage des patins

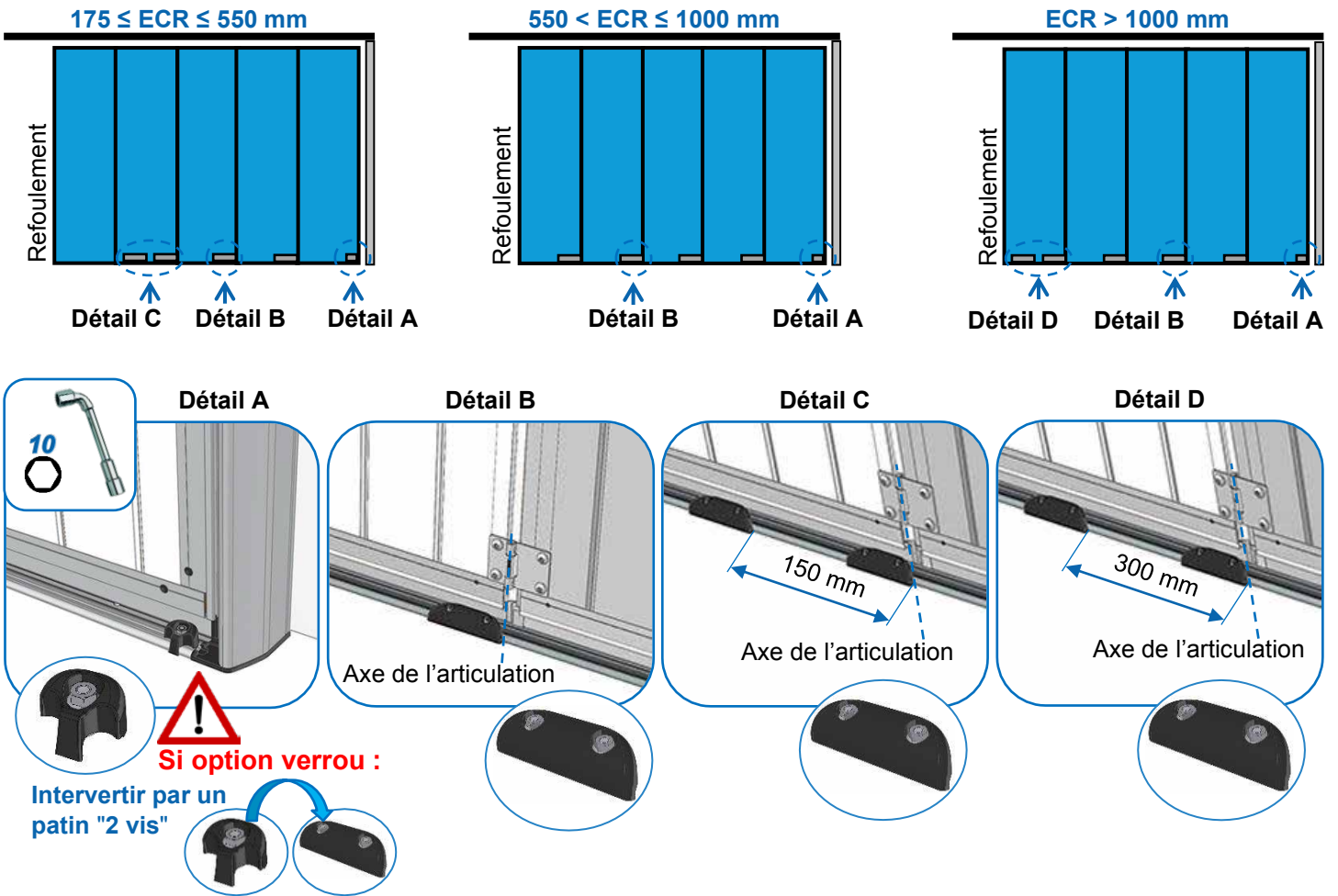

Montage du guidage

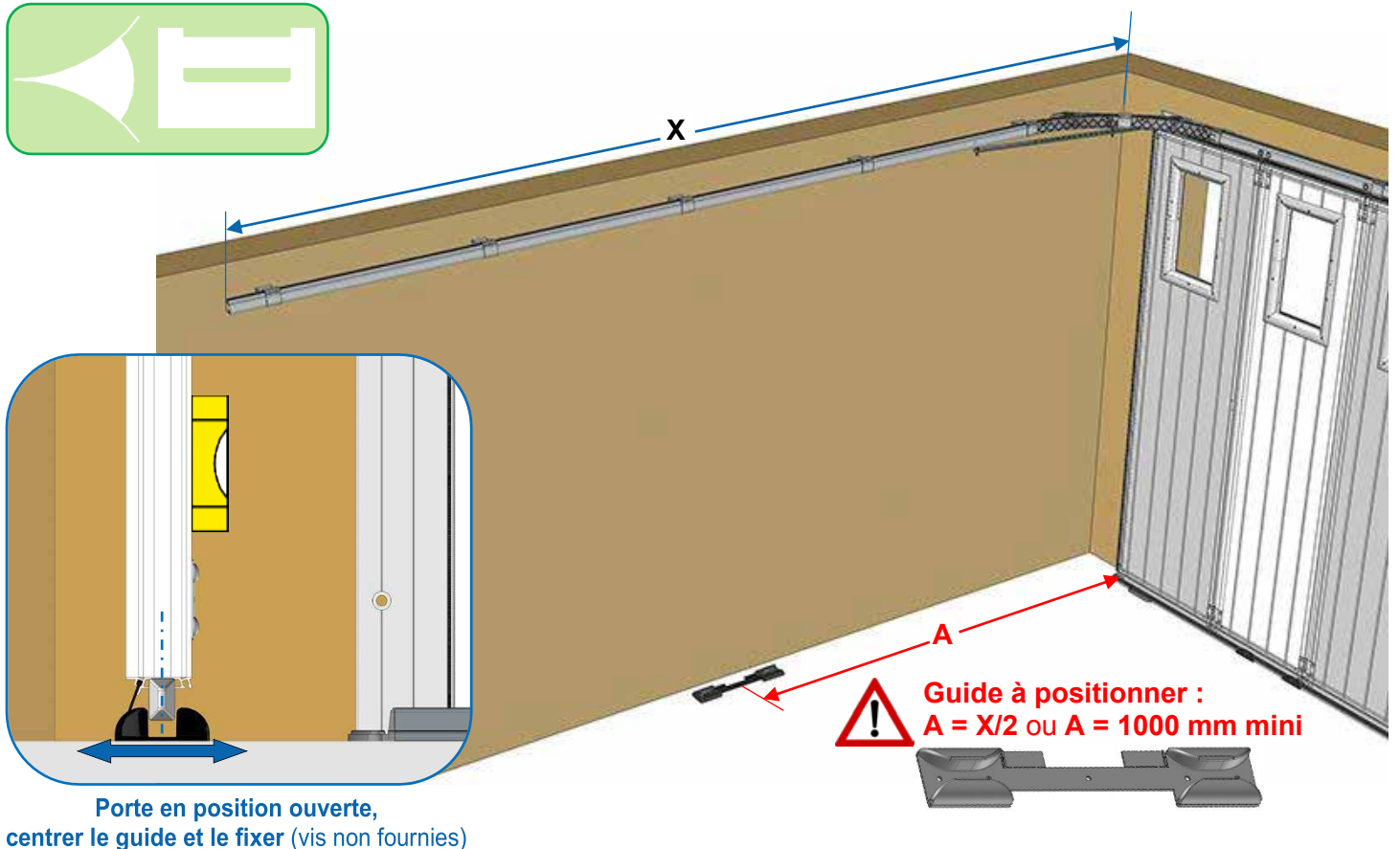

Système de placage du tablier (panneau côté refolement)

IMPORTANT

Si HP ≤ 2500 mm, alors 1 système de placage

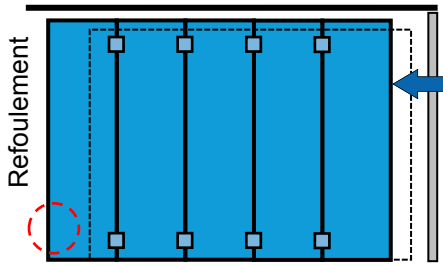

Si HP > 2500 mm, alors 2 systèmes de placage

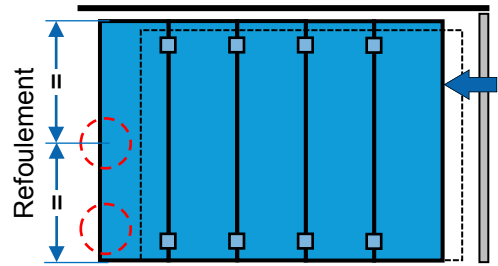

OU

• $225 \leq \text{ECR} < 600 \text{ mm}$:

1 - Assembler la chape support

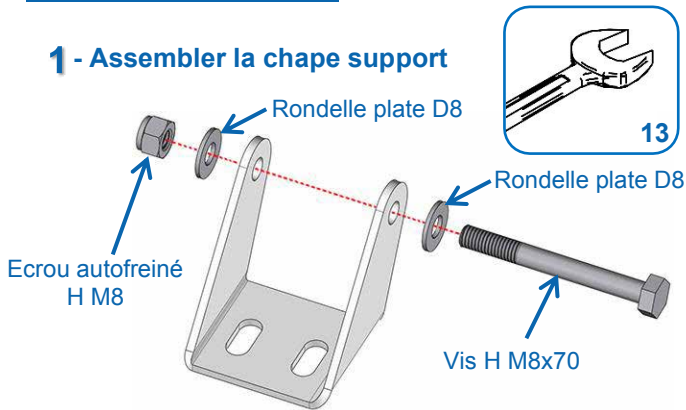

Visser sur les axes de trusquin

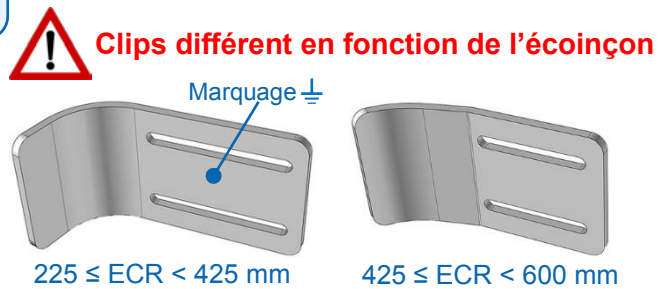
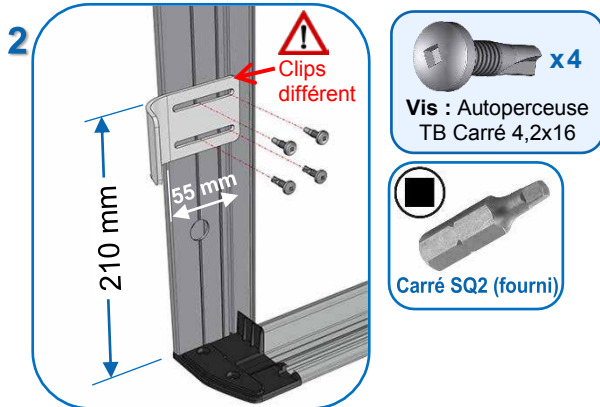

3 Centrer sur le clips enroulé

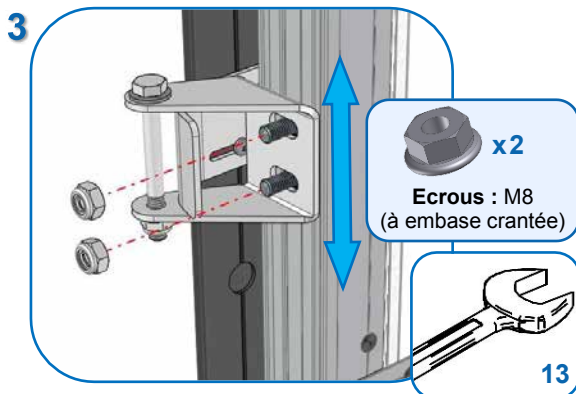

En contact

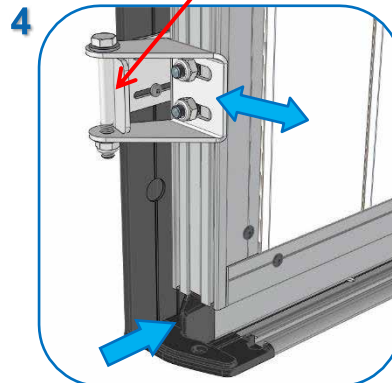

- A- Appuyer sur le bas du panneau
- B- Tirer la chape support
- C- Bloquer les écrous

• **ECR ≥ 600 mm :**

Visser sur l'axe de trusquin

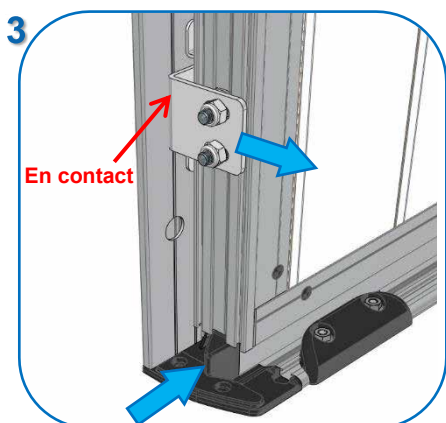
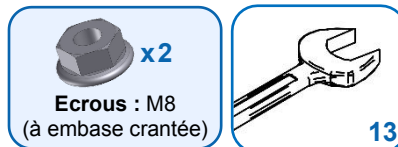
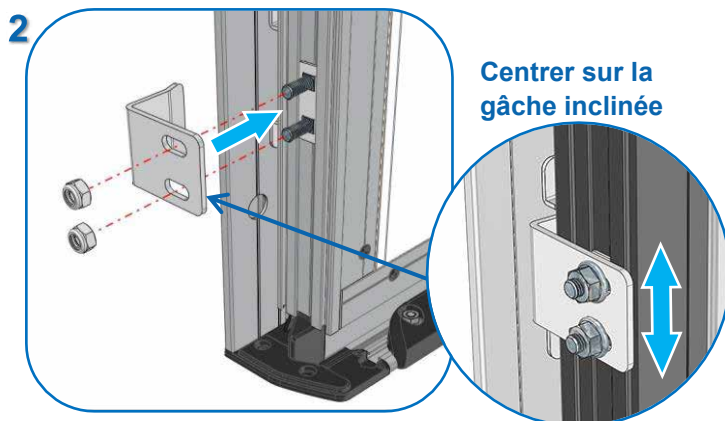
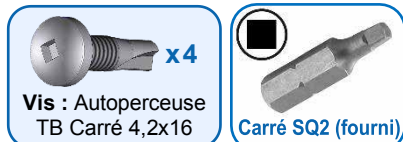
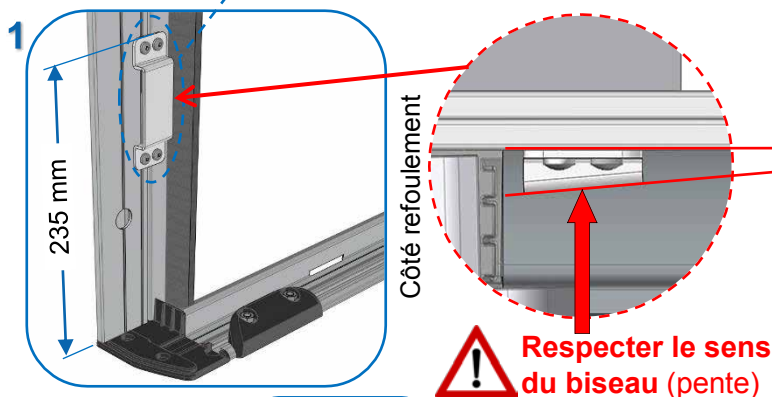

- 1- Appuyer sur le bas du panneau
- 2- Tirer le clips angulaire
- 3- Bloquer les écrous

Options

Serrure : Montage de la rosace

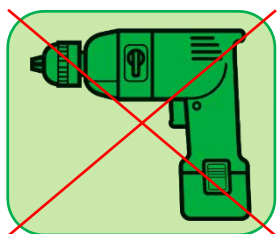

Utiliser un tournevis

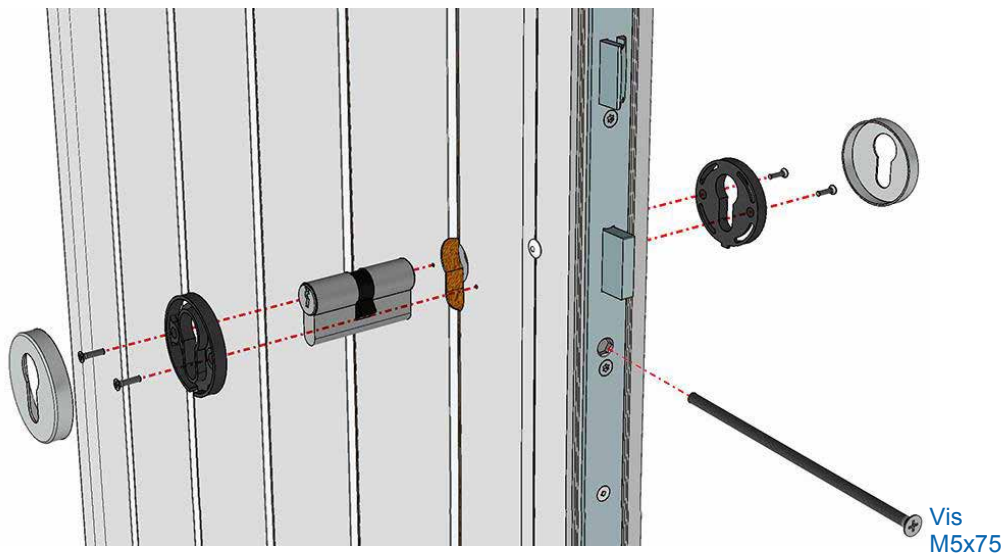

Montage de la poignée encastrée

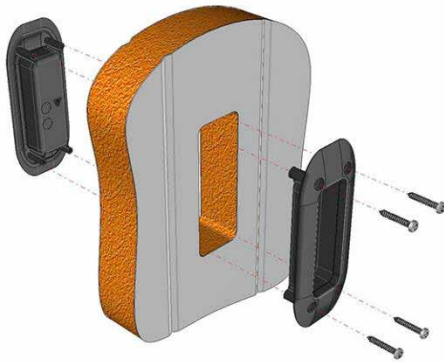

Les vis sont côté intérieur



Montage du verrou bas

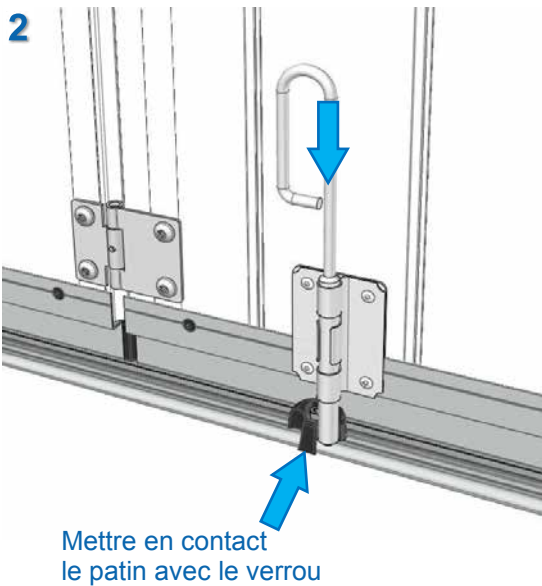
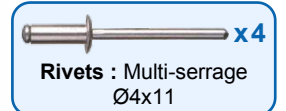
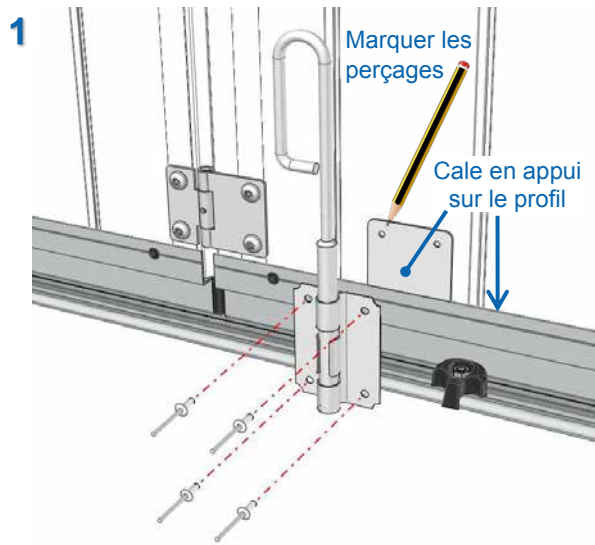
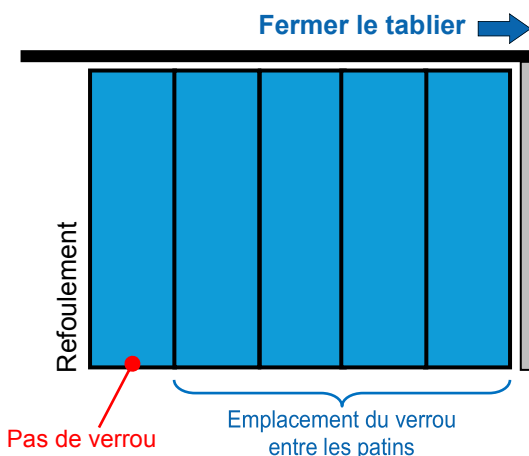

Ouvrir le verrou puis le tablier

3

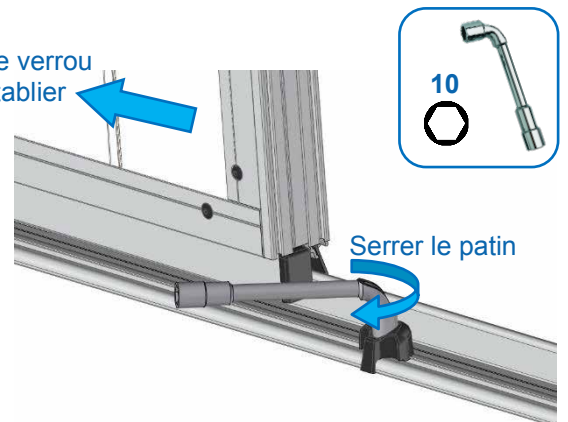

Montage du verrou haut (HP = 2200 mm maxi)

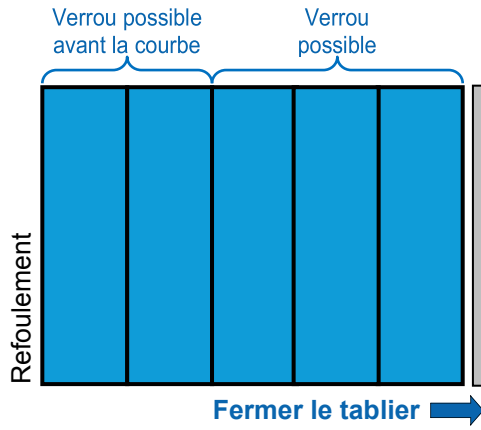

! Pas de verrou :
Si moteur au plafond ou au linteau.

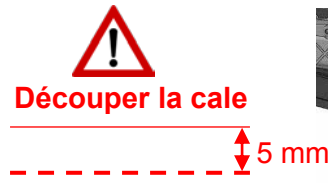

1 - Installer la cale

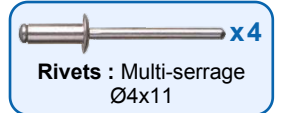
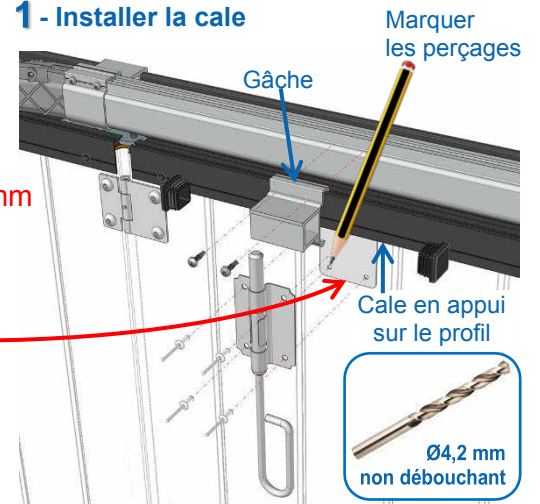

2 - Assembler la gâche et la clipser sur le rail

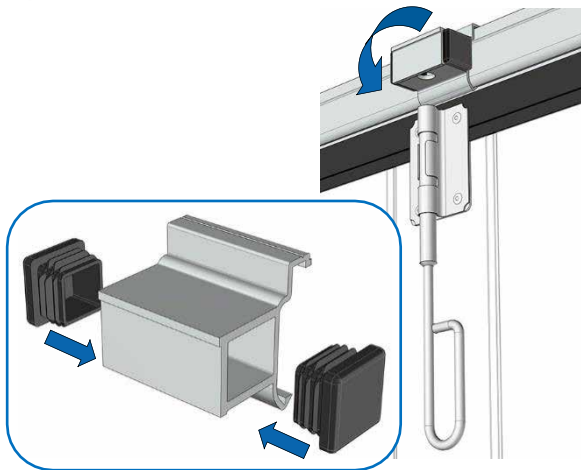

3 - Plaquer la gâche contre le verrou

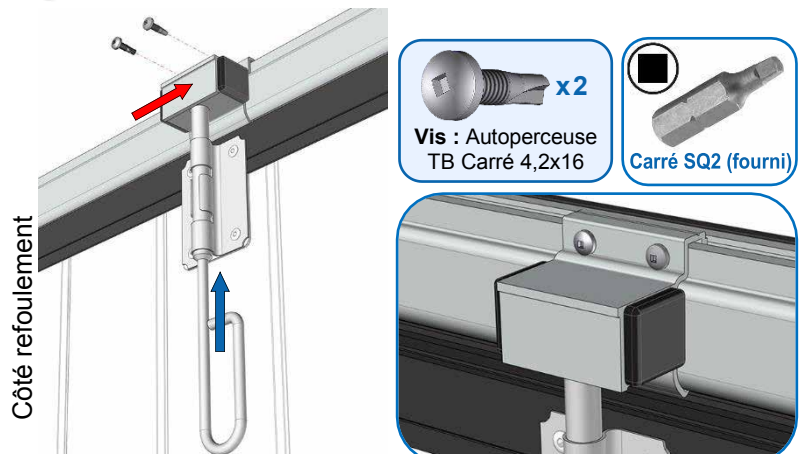

Tester le verrouillage

Montage pour écoinçon refoulement 1000 mm < ECR < Motorisation en baie

Préparation du support multi-moteurs



Si moteur SOMMER au plafond

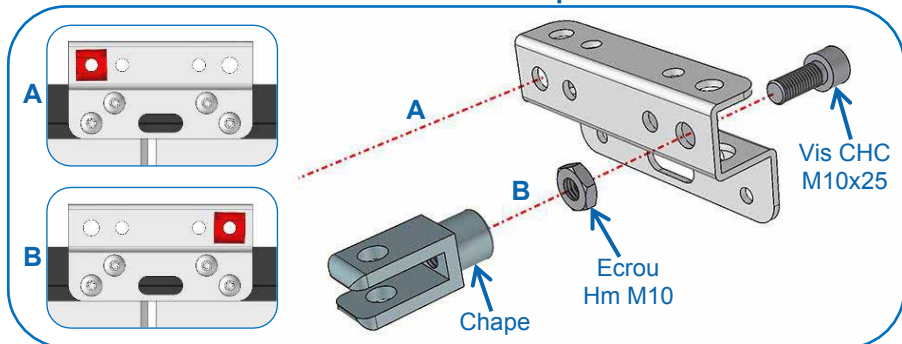

Si moteur SOMFY au plafond

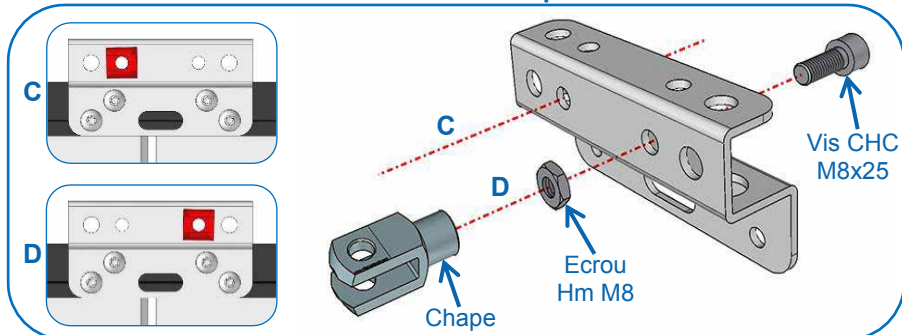

Si moteur SOMMER au linteau

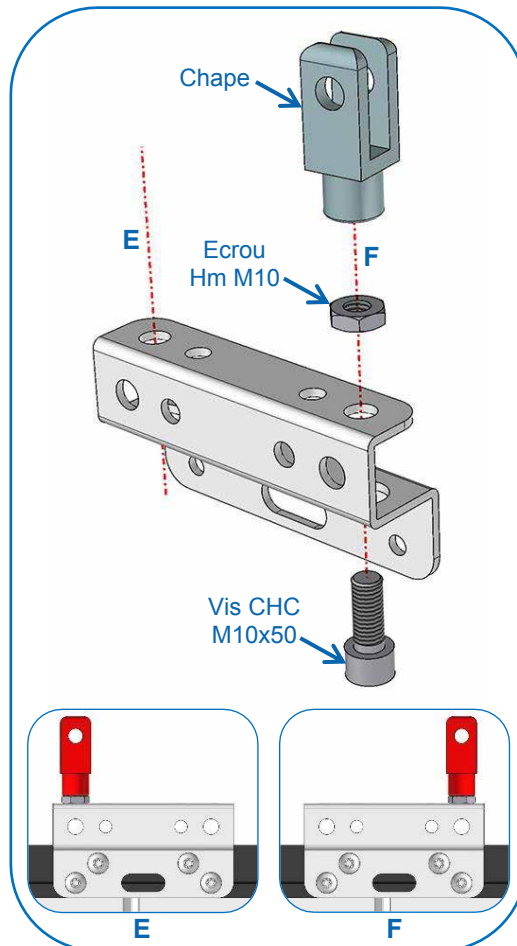

Moteurs	Au plafond		Au linteau	
	Refolement Gauche	Refolement Droite	Refolement Gauche	Refolement Droite
Sommer TD	B	A	F	E
Sommer Pro ⁺	A	B	E	F
Somfy	D	C	-	-

Montage du support multi-moteurs

Moteur SOMMER (au plafond ou au linteau) ou Moteur SOMFY (au plafond)

